

INSTRUCTION MANUAL

Serial Number _____

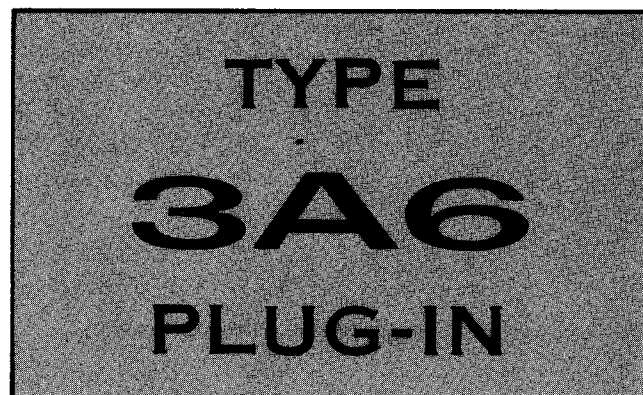

Tektronix, Inc.

S.W. Millikan Way ● P. O. Box 500 ● Beaverton, Oregon 97005 ● Phone 644-0161 ● Cables: Tektronix



WARRANTY

All Tektronix instruments are warranted against defective materials and workmanship for one year. Tektronix transformers, manufactured in our own plant, are warranted for the life of the instrument.

Any questions with respect to the warranty mentioned above should be taken up with your Tektronix Field Engineer.

Tektronix repair and replacement-part service is geared directly to the field, therefore all requests for repairs and replacement parts should be directed to the Tektronix Field Office or Representative in your area. This procedure will assure you the fastest possible service. Please include the instrument Type and Serial number with all requests for parts or service.

Specifications and price change privileges reserved.

Copyright © 1964 by Tektronix, Inc., Beaverton, Oregon. Printed in the United States of America. All rights reserved. Contents of this publication may not be reproduced in any form without permission of the copyright owner.



**TYPE 3A6
DUAL-TRACE
AMPLIFIER**

VARIABLE
VOLTS/DIV

1 MEG
47 pf

POSITION

CH 1

AC
DC
GND

1
2
5
10
.5
.2
.1
.05
.02
.01

UNCAL

DC BAL

MODE

INV (CH 1) NORM
CH 1

CALIB

CALIB

CH 2

VARIABLE
VOLTS/DIV

AC
DC
GND

ALTER

CHOP

ADDED

CH 2

1
2
5
10
.5
.2
.1
.05
.02
.01

UNCAL

DC BAL

POSITION

TRIGGER
CH1 ONLY
PULL

SERIAL

1 MEG
47 pf

TEKTRONIX, INC.
PORTLAND, OREGON, U. S. A.

Type 3A6 Dual-Trace Amplifier



CONTENTS

	Warranty
Section 1	Characteristics
Section 2	Operating Instructions
Section 3	Circuit Description
Section 4	Maintenance
Section 5	Calibration
Section 6	Parts List and Diagrams

A list of abbreviations and symbols used in this manual will be found on page 6-1. Change information, if any, is located at the rear of the manual.

SECTION 1

CHARACTERISTICS

Introduction

The Type 3A6 Dual-Trace Amplifier plug-in unit contains two identical amplifier channels. Either channel can be used independently for a single-trace display, or the two channels can be electronically switched for a dual-trace display. Also, the two channels can be added algebraically and the resultant waveform displayed on the indicator unit crt.

A signal delay line in the plug-in unit delays the signal to be displayed while the triggering signal passes to the time base undelayed. This allows the leading edge of the triggering signal to be viewed on the crt.

The Type 3A6 can be used with any of the Tektronix 560-Series Oscilloscopes* or with the Tektronix Type 129 Plug-In Unit Power Supply.

Frequency Response

Dc to 10 mc (not more than 3 db down at 10 mc) with a corresponding risetime of typically 35 nanoseconds.

Deflection Factors

Ten calibrated steps for each channel: .01, .02, .05, .1, .2, .5, 1, 2, 5 and 10 volts/division. Variable control in each channel permits continuous, uncalibrated adjustment from 0.01 to about 25 volts/division in conjunction with the step switch.

Accuracy

Within $\pm 3\%$ of indicated deflection with VARIABLE in the CALIB position.

Input Impedance

1 megohm $\pm 1\%$, paralld by about 47 pf.

Input Coupling

Ac or dc coupled, selected by front-panel switch. In the

*Cannot be used with a Type 560. Also, when used with a Type 2B67 or 3B2 time-base plug-in unit or with a Type 565 or RM565, it may not be possible to view the entire leading edge of the triggering waveform due to the delay of these time-base circuits.

AC position low-frequency response is limited to about 2 cps (0.2 cps with $10\times$ passive probe).

Maximum Input Voltage

600 volts combined dc and peak ac; 600 volts peak-to-peak ac.

Polarity Inversion

Polarity of Channel 1 can be changed to provide 180° inversion. No polarity inversion of Channel 2.

Operating Modes

Channel 1 only.

Channel 2 only.

Alternate between channels.

Chopped between channels at approximately 150 kc rate.

Added Algebraically.

Channel Isolation

50,000:1 or greater at 100 kc.

Triggering

Internal triggering signals for time base are provided from both channels or from Channel 1 only, determined by front-panel switch.

Mechanical Features

Input connectors: BNC jacks.

Construction: Aluminum alloy chassis and panel.

Accessories

Information on accessories for use with this instrument is included at the rear of the mechanical parts list.

SECTION 2

OPERATING INSTRUCTIONS

FUNCTION OF FRONT-PANEL CONTROLS AND CONNECTORS

The function of all controls and connectors except the CALIB, MODE, INV (CH 1) NORM and TRIGGER CH 1 ONLY are identical for both channels.

Input	Signal input connector.
POSITION	Controls vertical position of the display.
VOLTS/DIV	Selects vertical deflection factor. (VARIABLE control must be in CALIB position for deflection factor indicated on front panel.)
VARIABLE	Provides continuously variable deflection factor to about 2.5 times setting of VOLTS/DIV switch.
UNCAL	Light indicates that VARIABLE control is not set to CALIB.
DC BAL	Screwdriver adjustment to set dc balance of the amplifier.
AC DC GND	Selects signal coupling method. AC: Blocks dc component of applied signal. DC: Directly couples the applied signal to grid of input stage. GND: Grounds grid of input stage (does not ground applied signal).
CALIB	Screwdriver adjustment to set the basic deflection factor of the plug-in unit.
MODE	Selects mode of operation. CH 1: Displays Channel 1 signal only. CH 2: Displays Channel 2 signal only. ALTER: Dual-trace display of both Channel 1 and 2 signals. Display is switched between channels at end of each sweep. CHOP: Dual-trace display of both Channel 1 and 2 signals. Display is switched between channels at about 150 kc rate. ADDED: Displays algebraic sum of Channel 1 and Channel 2 signals.
INV (CH 1) NORM	Inverts the Channel 1 display when in the INV position.
TRIGGER CH 1 ONLY PULL	Selects triggering from Channel 1 signal when pulled out. When pushed in, triggering signal is obtained from combined Channel 1 and Channel 2 signal.

FIRST-TIME OPERATION

The following steps are intended to acquaint the operator with the basic overall operation and function of the Type

3A6. More specific operation and basic application information is given later in this section.

1. Insert the Type 3A6 into the left-hand (Y-axis) plug-in compartment of the indicator unit. Insert a time-base plug-in unit such as a Tektronix Type 3B1 or 3B3 into the right-hand (X-axis) plug-in compartment (except with Type 565 or RM565).

2. Set the front-panel controls as follows:

AC DC GND	DC (both channels)
VOLTS/DIV	.5 (both channels)
VARIABLE	CALIB (both channels)
POSITION	Midrange (both channels)
MODE	CH 1
INV (CH 1) NORM	NORM
TRIGGER	Pushed in

3. Turn on the indicator unit power. If there is any doubt as to the operation of the indicator unit or time base, see the instruction manuals for these units.

4. Set the indicator unit calibrator for 1 volt output and the time-base for a sweep rate of 5 milliseconds.

5. Connect the calibrator output to both the Channel 1 and Channel 2 input connectors. Adjust the time-base triggering controls for a stable display.

6. Turn the Channel 1 POSITION control to move the display above the graticule centerline.

7. Set the MODE switch to CH 2. A two-division display similar to the previous display should be seen. Turn the Channel 2 POSITION control to move the display below the graticule centerline.

8. Set the MODE switch to ALTER; the Channel 1 and 2 displays as set up in steps 6 and 7 should be seen. Turn the time-base time/division switch to a faster sweep rate. Notice that the flicker between traces decreases as the sweep rate is increased. Return the time/division switch to 5 milliseconds.

9. Set the AC DC GND switch to AC. Notice the differentiation of the 60-cycle calibrator waveform which indicates loss of low frequencies due to the coupling capacitor. Return the switch to the DC position.

10. Turn one of the VARIABLE controls throughout its range. The deflection of that channel should decrease by a factor of about 2.5 to 1. Return the VARIABLE to CALIB.

11. Set the MODE switch to CHOP; the display should be identical to ALTER but with less flicker between traces. Turn the time-base time/division switch to 10 microseconds. Notice the switching between channels as shown by the segmented trace. Reduce the sweep rate slowly and notice that the trace appears solid at about 0.1 milliseconds. This is the fastest sweep rate at which CHOP mode can be used and still obtain a satisfactory display.

Operating Instructions—Type 3A6

12. Set the time/division switch to 2 microseconds and readjust the triggering controls for a stable display. Turn the intensity up slightly and notice the overshoot on the display. This is the switching transient between the channels. Set the crt cathode selector switch on the indicator unit rear-panel to chopped blanking. The switching transient should be removed from the display. Return the time/division switch to 5 milliseconds and the crt cathode selector switch to the normal position.

13. Set the MODE switch to ADDED. The display should be 4 divisions in amplitude. The Channel 1 and 2 signals (2 divisions each) are added for this display. Note that either POSITION control will move the trace.

14. Set the INV (CH 1) NORM switch to INV. The display should be a straight line. Since both displays are two divisions in amplitude but of opposite polarity, the algebraic sum is zero.

15. Set either VOLTS/DIV switch to 1. A square wave is again displayed indicating that the algebraic sum of Channel 1 and 2 is no longer zero.

CALIB Adjustment

Whenever the Type 3A6 is inserted into a plug-in compartment, check and adjust the gain to compensate for the differences between indicator units. Allow about 10 minutes warmup before performing this adjustment.

1. Set both AC DC GND switches to DC.
2. Set the MODE switch to CH 1.
3. Set both VOLTS/DIV switches to .02.
4. Turn the VARIABLE controls fully clockwise so the UNCAL lights are off.
5. Set the time-base controls for automatic triggering.
6. Connect the calibrator output to Channel 1 input.
7. Set the indicator unit calibrator to 100 millivolts.
8. Set the CALIB control for exactly 5 major divisions of deflection.
9. Set the MODE switch to CH 2.
10. Connect the calibrator output to Channel 2 input.
11. The deflection should be exactly 5 divisions. If incorrect, refer to the Channel 2 gain adjust procedure in Section 5.

DC BAL Adjustment

Check. To check the dc balance of either channel, set the AC DC GND switch to GND and the VOLTS/DIV switch to .01. Set the time-base controls for automatic triggering. Rotate the VARIABLE control throughout its range. If the trace moves vertically, adjust the DC BAL control according to the procedure which follows.

Adjustment. The following procedure can be used to adjust the dc balance of either channel. Set the MODE switch to display the desired channel. Allow about 10 minutes warmup before performing this adjustment.

1. Set the AC DC GND switch to GND.
2. Set the VOLTS/DIV switch to .01.
3. Set the time-base controls for automatic triggering.
4. Turn the POSITION control to mid-range.
5. With the VARIABLE control in the CALIB position adjust the DC BAL control to bring the trace near graticule center.
6. Turn the VARIABLE control fully counterclockwise and position the trace to the graticule centerline with the POSITION control.
7. Return the VARIABLE control to the CALIB position. Measure the exact distance the trace is displaced above or below the centerline.
8. Adjust the DC BAL control to move the trace exactly half this distance (measured in step 7) past the graticule centerline.

NOTE

Both DC BAL controls are the dual-range or coarse-fine type. To use this type of control, turn the control slightly past the desired point of adjustment (coarse adjust). Then, reverse the direction of rotation and use the fine adjustment (about 30° range) to establish balance.

9. Check the balance by rotating the VARIABLE control throughout its range. If the amplifier is not properly balanced, repeat steps 6, 7 and 8.

Signal Connections

In general, 10× attenuator probes offer the best means of coupling a signal to the input of the Type 3A6. The 10× attenuator probe offers a higher input impedance and allows the circuit under test to operate more closely to actual operating conditions. The signal probes are shielded to prevent pickup of any electrostatic or electromagnetic interference.

In some cases, the signal can be connected to the Type 3A6 inputs with short unshielded leads. This is particularly true with high-level, low-frequency signals. When such leads are used, be sure to establish a common ground between the Type 3A6 and the equipment under test. Attempt to position the leads away from any stray interference to avoid errors in the display. If interference is excessive with unshielded leads, use a coaxial cable or a probe.

In high frequency applications requiring maximum overall bandwidth, use coaxial cables terminated in their characteristic impedance at the input of the Type 3A6.

Loading Effect of the Type 3A6

As nearly as possible, simulate actual operating conditions in the equipment under test. Otherwise, the equipment under test may not produce a normal signal. The 10× attenuator probes mentioned previously offer the least circuit loading. Tektronix 10× attenuator probes have an input resistance of 10 megohms with very low shunt capacitance.

When the signal is coupled directly to the input of the Type 3A6, the input impedance is 1 megohm ($\pm 1\%$) paralleled by about 47 pf. When the signal is coupled to the input of the Type 3A6 through a coaxial cable, the input capacitance is greatly increased. Just a few feet of coaxial cable can increase the input capacitance to well over 100 pf.

Input Coupling

The Channel 1 and 2 AC DC GND switches allow a choice of input coupling. To display both the ac and dc components of an applied signal set the switch to DC. In the AC position, only the ac component of the input signal is allowed to pass. The GND position connects the input grid to ground but does not ground the input signal.

The DC position can be used for most applications. However, if the dc component of the signal is large enough to drive the display off the crt viewing area or if the dc component is such larger than the ac component, use the AC position.

In the AC position of the switch, the dc component of the signal is blocked by a capacitor in the input circuit. The low-frequency response in the AC position is about 2 cps, 3 db down. Therefore, some low-frequency distortion can be expected near this frequency limit. Distortion will also appear in square waves which have low-frequency components.

The GND position provides a ground reference at the input of the Type 3A6. The signal applied to the input connector is internally disconnected but not grounded. The grid of the input tube is at ground potential, eliminating the need to externally ground the input to establish a zero dc reference.

Internal Triggering

Single-Trace Displays. In the CH 2 and ADDED positions of the MODE switch, push the TRIGGER switch in. When the time-base trigger coupling switch is set to dc, the setting of the POSITION controls will affect the setting of the trigger level control. Proper triggering can be obtained in the CH 1 position of the MODE switch in either TRIGGER switch position. However, in the CH 1 ONLY position (TRIGGER switch pulled out) the POSITION controls have no effect on dc triggering.

Dual-Trace Displays. To obtain proper triggering in the CHOP mode, pull out the TRIGGER switch. Then, the internal trigger signal coupled to the time base does not contain the dual-trace chopping signal. It is difficult to get a stable display if the TRIGGER switch is pushed in because of the 150 kc dual-trace chopping signal.

In the ALTER mode the TRIGGER switch can be in either position, depending upon the application. When the TRIGGER switch is pushed in, the time base will be triggered from the display of each channel. This provides stable display of two unrelated signals but does not indicate the time relationship between the signals. To display signals showing true time relationship, pull the TRIGGER switch out to trigger from Channel 1 only. If the signals on the two channels are not harmonically related, the Channel 2 display will not be stable.

In the ALTER mode with the TRIGGER switch pushed in, do not set the time-base trigger coupling switch to dc.

Dual-Trace Operation

Chopped Mode. The chopped display is produced by electronic switching between channels. To blank out the switching transients, set the CRT Cathode Selector switch on the rear of the indicator unit to the chopped blanking position.

In general, use the CHOP position (chopped-mode operation) with sweep rates slower than 0.1 millisecond/division. At higher sweep rates the chopped switching becomes apparent.

Two signals which are harmonically related can be displayed in the chopped mode showing true time relationship. However, if the signals are not harmonically related, the Channel 2 display will appear unstable.

Single-shot, transient or random signals which occur within the time interval determined by the time-base time/division switch (10 times sweep rate) can be compared using the chopped mode. To trigger the sweep, the Channel 1 signal must precede the Channel 2 signal. Since the signals show true time relationship, time difference measurements can be made.

Alternate Mode. The ALTER position (alternate-mode operation) can be used at any sweep rate. However, for time comparison measurements requiring sweep rates below about 20 milliseconds/division, use the chopped mode for best results.

Algebraic Addition

In many applications the desired signal is superimposed on an undesired signal such as line frequency hum, line noise, etc. Algebraic addition in the ADDED position of the MODE switch can be used in many cases to improve the ratio of desired to undesired signal. To do this, set up the instrument as follows:

1. Connect the source which contains both the desired and undesired signals to Channel 1 input.
2. Connect a source which contains only the undesired signal to Channel 2 input.
3. Set the MODE switch to CHOP or ALTER, whichever mode provides the best display at the sweep rate used.
4. The undesired portions of the signal on Channel 1 and 2 must be of opposite polarity. If they are of the same polarity, set the INV (CH 1) NORM switch to INV.
5. Adjust the Channel 1 VOLTS/DIV switch so the desired portion of the display is large enough for proper viewing.
6. Adjust the Channel 2 VOLTS/DIV switch for about the same amplitude as the undesired signal on Channel 1. Use the Channel 2 VARIABLE to match the deflection more closely.
7. Set the MODE switch to ADDED.
8. Readjust the Channel 2 VARIABLE or VOLTS/DIV switch to cancel out the maximum amount of undesired signal.
9. If the Channel 1 VARIABLE control is left in the CALIB position (UNCAL light off), the amplitude of the desired signal can be determined directly from the crt display and the Channel 1 VOLTS/DIV setting.

Operating Instructions—Type 3A6

NOTE

The TRIGGER switch should be pushed in to obtain the triggering signal from the algebraically added signal only. If pulled out, the time base will be triggered by the undesired signal and may result in an unstable display.

In addition to common-mode rejection applications as described above, the ADDED mode can be used for differential applications (signal addition and subtraction), dc offset or other applications. An example of the use of dc offset would be a low-frequency signal on a large dc level that could not be positioned on the display area. Ac coupling cannot be used because the input time-constant would distort the signal. However, the ac signal could be displayed using dc coupling if the dc level were not present. The dc level can be effectively removed by applying a dc offset voltage to one channel and the signal to the opposite channel. With the MODE switch in the ADDED position, increase the offset voltage until the ac signal can be viewed on the screen.

When signals are being displayed in the ADDED mode, these precautions should be observed:

Do not exceed the input voltage rating of the amplifier.

Do not apply signals that will exceed an equivalent of 20 major divisions of deflection. As an example, with a VOLTS/DIV switch setting of 1, the voltage applied to that channel's input connector should not exceed 20 volts. If this limit is exceeded, signal distortion will result.

Before displaying signals in the ADDED mode, set the MODE switch to ALTER or CHOP and position both channel signals to the center of the display area. This is also a precaution against display distortion.

BASIC APPLICATIONS

The following information describes the procedures and techniques for making basic measurements with a Type 3A6 and an associated Tektronix indicator unit and time base. No attempt has been made to describe these applications in detail as each one must be adapted to the individual requirements. Familiarity with the Type 3A6 will enable these basic techniques to be applied to a wide variety of uses.

In the following procedures it is assumed that the Type 3A6 is placed in the left-hand or vertical compartment of the indicator unit and an appropriate time-base unit is placed in the right-hand compartment (except in a Type 565).

Voltage Measurements—AC

To measure the voltage level of an ac signal, set the AC DC GND switch to AC. In this position the dc component of the signal will be blocked. However, if the ac signal is very low frequency, the DC position should be used to avoid distortion of the signal.

To make a peak-to-peak measurement, use the following procedure:

1. Set the VOLTS/DIV switch to a setting at least $\frac{1}{8}$ of the expected voltage. For example, if the voltage will be about 10 volts in amplitude, set the VOLTS/DIV switch to 2 (.2 if $10\times$ probe is used).

2. Apply the signal to either input connector.
3. Set the MODE switch to the channel used.
4. Set the AC DC GND switch to AC.

5. Set the time-base triggering controls to obtain a stable display. Set the time/division switch to a position that will display several cycles of the waveform.

6. Turn the POSITION control so that the lower portion of the waveform coincides with one of the graticule lines below the centerline. With the time-base Position control, move the display so one of the upper peaks lies near the vertical centerline (see Fig. 2-1).

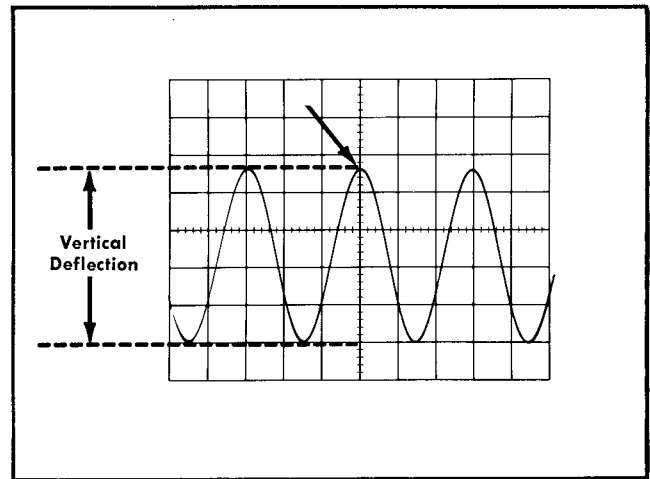

Fig. 2-1. Measuring the peak-to-peak voltage of a waveform.

7. Measure the divisions of vertical peak-to-peak deflection. Make sure the VARIABLE control is in the CALIB position.

8. Multiply the peak-to-peak distance measured in step 6 by the VOLTS/DIV setting. Also include the attenuation factor of the probe, if any.

As an example of this method of measurement, assume that the peak-to-peak vertical deflection is 4.6 divisions (see Fig. 2-1) using a $10\times$ probe and a VOLTS/DIV setting of .5. Using the formula:

$$\text{Volts peak-to-peak} = \text{vertical deflection (divisions)} \times \text{VOLTS/DIV setting} \times \text{probe attenuation factor}$$

Substituting the values given above:

$$\text{Volts peak-to-peak} = 4.6 \times .5 \times 10$$

The peak-to-peak voltage would be 23 volts.

Voltage Measurements—Instantaneous DC

To measure the dc level at a given point on a waveform, use the following procedure:

1. Set the VOLTS/DIV switch to a setting at least $\frac{1}{8}$ of the expected voltage. For example, if the voltage will be about 10 volts in amplitude, set the VOLTS/DIV switch to 2 (.2 if $10\times$ probe is used).

2. Connect the signal to either input connector.
3. Set the MODE switch to the channel used.
4. Set the AC DC GND switch to GND.
5. Adjust the triggering controls for automatic triggering.
6. Align the trace with the bottom line of the graticule or other reference line. If the voltage is negative with respect to ground, set the INV (CH 1) NORM switch to INV and then align the trace with the reference line. Do not move the POSITION control after this reference line has been established.

NOTE

To measure a voltage level with respect to another voltage rather than ground, make the following changes in the above procedure. Set the AC DC GND switch to DC. Apply the reference voltage to the input and position the trace to the reference line.

7. Set the AC DC GND switch to DC. The ground reference can be checked at any time by switching to the GND position.
8. Set the time-base triggering controls to obtain a stable display. Set the time/division switch to a setting that will display several cycles of the waveform.
9. Measure the distance in divisions between the ground reference line established in step 6 and the point on the waveform to be measured. For example, in Fig. 2-2 the measurement is made between points (a) and (b).

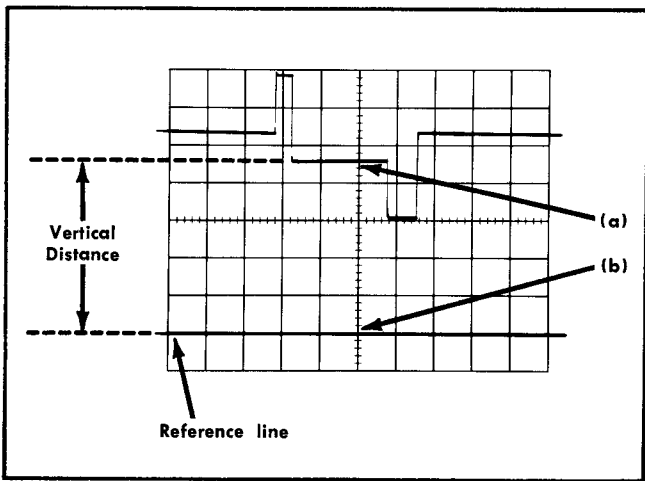

Fig. 2-2. Measuring instantaneous dc voltage with respect to a reference.

10. Establish the polarity of the signal. If the waveform is above the reference line with the INV (CH 1) NORM switch set to NORM, the voltage is positive. If the INV (CH 1) NORM switch is set to INV, the voltage is negative.
11. Multiply the distance measured in step 8 (include polarity) by the VOLTS/DIV setting. Include the attenuation factor of the probe, if any.

As an example of this method of measurement, assume that the vertical distance is 4.6 divisions (see Fig. 2-2), INV (CH 1) NORM switch set to INV, using a 10× probe and a VOLTS/DIV setting of 2.

Using the formula:

$$\text{Instantaneous Voltage} = \text{vertical distance (divisions)} \times \text{polarity} \times \text{VOLTS/DIV setting} \times \text{probe attenuation factor}$$

Substituting the values given above:

$$\text{Instantaneous Voltage} = 4.6 \times -1 \times 2 \times 10$$

The instantaneous voltage would be -92 volts.

Voltage Comparison Measurements

In some applications it may be necessary to establish a set of deflection factors other than those indicated by the VOLTS/DIV switch. This is useful for comparing signals which are exact multiples of a reference voltage amplitude. To establish a set of deflection factors based upon some specific reference amplitude, proceed as follows:

1. Apply a reference signal of known amplitude to the Channel 1 input connector and adjust the size of the display for an exact number of graticule divisions using the Channel 1 VOLTS/DIV switch and VARIABLE control. Do not move the VARIABLE control after obtaining the desired deflection.
2. Divide the amplitude of the reference signal (volts) by the product of the deflection in divisions (established in step 1) and the VOLTS/DIV switch setting. This is the Deflection Conversion Factor.

$$\text{Deflection Conversion Factor} = \frac{\text{Reference signal amplitude (volts)}}{\text{Deflection (divisions)} \times \text{VOLTS/DIV setting}}$$

3. To calculate the Adjusted Deflection Factor at any setting of the Channel 1 VOLTS/DIV switch, multiply the VOLTS/DIV switch setting by the Deflection Conversion Factor obtained in step 2.

$$\text{Adjusted Deflection Factor} = \text{VOLTS/DIV setting} \times \text{Deflection Conversion Factor}$$

This Adjusted Deflection Factor applies only to Channel 1 and is correct only if the VARIABLE control is not moved from the position set in step 1.

4. To determine the peak-to-peak amplitude of a signal compared to a reference, disconnect the reference and apply the signal to Channel 1.
5. Set the Channel 1 VOLTS/DIV switch to a setting that will provide sufficient deflection to make the measurement. Do not readjust the VARIABLE control.

6. Measure the vertical deflection in divisions and determine the amplitude by the following formula:

$$\text{Signal Amplitude} = \text{Adjusted Deflection Factor} \times \text{Deflection (divisions)}$$

As an example of this method of measurement, assume a reference signal amplitude of 30 volts, a VOLTS/DIV setting

Operating Instructions—Type 3A6

of 5 and a deflection of 4 divisions. Substituting these values in the Deflection Conversion Factor formula (step 2):

$$\text{Deflection Conversion Factor} = \frac{30}{4 \times 5} = 1.5$$

Then, with a VOLTS/DIV switch setting of 10 the Adjusted Deflection factor (step 3) would be:

$$\text{Adjusted Deflection Factor} = 10 \times 1.5 = 15 \text{ volts/division}$$

To determine the peak-to-peak amplitude of an applied signal which produces a vertical deflection of 4.5 divisions use the Signal Amplitude formula (step 6):

$$\text{Signal Amplitude} = 15 \times 4.5 = 67.5 \text{ volts}$$

Time-Difference Measurements

The calibrated sweep rate of the time base and the dual-trace feature of the Type 3A6 allow measurement of time difference between two events. To measure time difference, use the following procedure:

1. Set the AC DC GND switches to the same position, depending on the type of coupling desired.
2. Set the INV (CH 1) NORM switch to NORM.
3. Set the MODE switch to either CHOP or ALTER. In general, the CHOP position is more suitable for low-frequency signals and the ALTER position is more suitable for high-frequency signals. For more information on determining the mode, see "Dual-Trace Operation" and "Internal Triggering" in this section.
4. Pull the TRIGGER switch out to provide triggering from the Channel 1 signal only.
5. Set the VOLTS/DIV switches so that the voltages applied to the input connectors will provide suitable deflection on the crt.
6. Apply the reference signal to Channel 1 and the comparison signal to Channel 2. Use coaxial cables or probes which have equal time delay.
7. Set the triggering controls for a stable display.
8. Set the time/division switch for a sweep rate which shows a two to three division spacing between the two signals.
9. Adjust the POSITION control to center each display (or the points on the display between which the measurement is being made) in relation to the horizontal graticule center-line.
10. Measure the exact horizontal distance between the reference waveform and the Channel 2 waveform (see Fig. 2-3).
11. Multiply the measured distance by the setting of the time/division switch to obtain the apparent time interval. The actual time interval is determined by dividing this value by the sweep magnification, if sweep magnification is used.

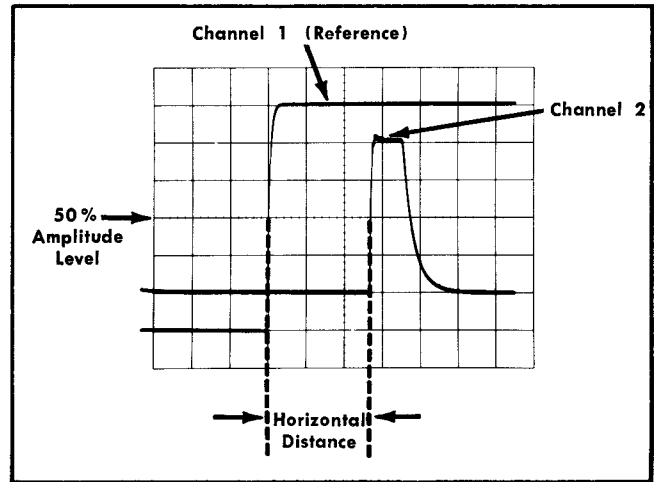

Fig. 2-3. Measuring time delay between pulses.

For example, assume that the time/division switch is set to 5 microseconds, the $5\times$ magnifier is on and the horizontal distance between waveforms is 2.7 divisions (see Fig. 2-3).

Using the formula:

$$\text{Time Delay} = \frac{\text{TIME/DIV setting} \times \text{Horizontal Distance (divisions)}}{\text{Sweep Magnification}}$$

Substituting the values given above:

$$\text{Time Delay} = \frac{5 \times 2.7}{5}$$

The time delay would be 2.7 microseconds.

Phase Measurements

Phase comparison between two signals of the same frequency can be made using the dual-trace feature of the Type 3A6. To make the comparison, proceed as follows:

1. Follow the procedure given in the first seven steps under "Time-Difference Measurements."
2. Set the time/division control for a sweep rate which displays less than 1 cycle of the waveform.
3. Adjust the VARIABLE control so the displays are equal and at least six centimeters in height. Reset the VOLTS/DIV switches, if necessary, to obtain equal amplitude displays.
4. Move the waveforms to the center of the graticule with the POSITION controls.
5. Turn the Variable time/division control counterclockwise until 1 cycle of the reference signal (Channel 1 signal) occupies exactly 9 divisions horizontally. Each division of the graticule represents 40° of the cycle ($360^\circ \div 9 \text{ divisions} = 40^\circ/\text{division}$). See Fig. 2-4).
6. Measure the horizontal distance between corresponding points on the waveforms. Note whether the Channel 2 waveform is leading or lagging the reference waveform on Channel 1.

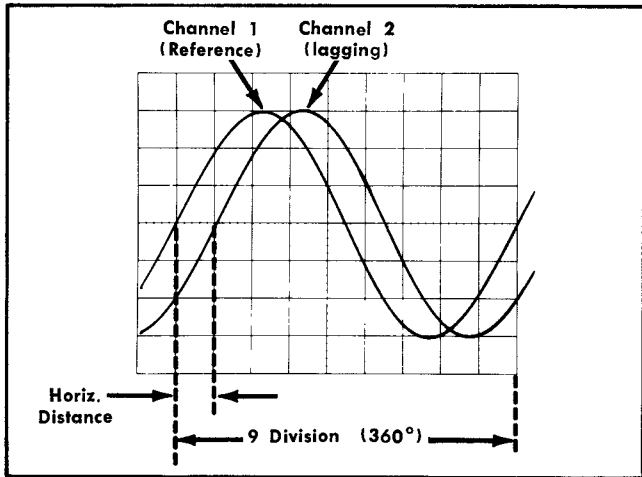

Fig. 2-4. Measuring phase shift.

7. Multiply the measured distance (in divisions) by 40° to obtain the exact amount of phase difference.

For example, with a horizontal distance of 1.1 divisions as shown in Fig. 2-4., the phase difference would be:

$$\text{Phase difference} = 1.1 \times 40^\circ = 44^\circ$$

8. Phase difference can be measured more accurately by increasing the sweep rate of the time base. Do not change

the setting of the variable time/division control. One of the easiest ways to increase the sweep rate is with the $5\times$ magnifier. The adjusted phase factor is determined by dividing 40° by the increase in sweep rate.

For example if the sweep rate were increased 5 times with the $5\times$ magnifier, the new phase factor would be $40^\circ \div 5 = 8^\circ/\text{division}$ (see Fig. 2-5).

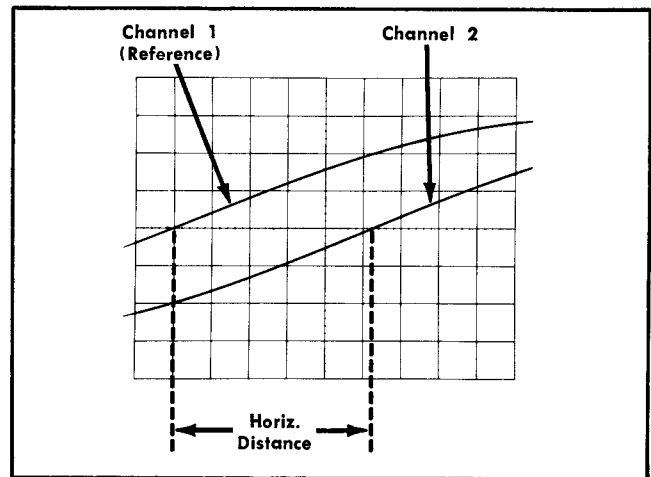

Fig. 2-5. Accurate phase measurement with sweep rate increased 5 times.

SECTION 3

CIRCUIT DESCRIPTION

The Type 3A6 Dual-Trace Amplifier contains two identical input channels, a common output amplifier, a switching circuit, and a trigger amplifier. The output of either or both input channel amplifiers may be fed to the output amplifier, depending on the condition of the switching circuit. Thus, the switching circuit makes it possible to display one signal as a single trace on the crt, two signals alternately in a dual-trace display, or the algebraic sum or difference of two signals as a single trace. Fig. 3-1 shows a block diagram of the Type 3A6.

Input Channel Amplifier

Each input channel consists of an attenuation network, an input cathode-follower, and a two-stage push-pull amplifier with switched outputs. Input cathode followers V113 and V123 (Channel 1) and V213 and V223 (Channel 2) isolate the attenuator input circuitry from emitter followers Q133 and Q143 (Channel 1) and Q233 and Q243 (Channel 2). Q134 and Q144 (Channel 1), and Q234 and Q244 (Channel 2) drive the Output Amplifier.

The gain of the last stage in each input amplifier is set by two internal calibration adjustments: R149 (Channel 1) and R249 (Channel 2) set the gain of the stage in the .01 position of the VOLTS/DIV switches, R147 (Channel 1) and R247 (Channel 2) set the gain of the stage in the remaining posi-

tions of the VOLTS/DIV switches. The VARIABLE controls increase emitter degeneration when moved from the CALIB position.

The input attenuators are resistive dividers with capacitive compensation. The attenuators maintain an input impedance of 1 megohm paralleled by about 47 pf. With the VOLTS/DIV switches in the .01 and .02 positions, input signals are fed directly to cathode-follower stages V113 and V213. In the VOLTS/DIV switch positions which provide an input deflection factor greater than 20 mv/div (.05 to 10), the attenuator sections are stacked. In the .05 position, the 2.5 \times attenuator increases the basic 20 mv/div deflection factor to 50 mv/div. The 5 \times attenuator is used to increase the deflection factor to 100 mv/div in the .1 position. These three positions (1 \times , 2.5 \times , and 5 \times) are used with the 10 \times or 100 \times attenuators in the higher deflection-factor positions of the VOLTS/DIV switch.

The DC BAL controls in the grid circuit of V123 and V223 adjust the balance of each input amplifier so current does not flow through R139 (Channel 1), and R239 (Channel 2) under no-signal conditions. Otherwise, the position of a no-signal trace would shift on the crt as the VARIABLE control was turned or gain adjustments were made.

In the INV position, the INV (CH 1) NORM switch (SW155) inverts the Channel 1 output to the diode gates.

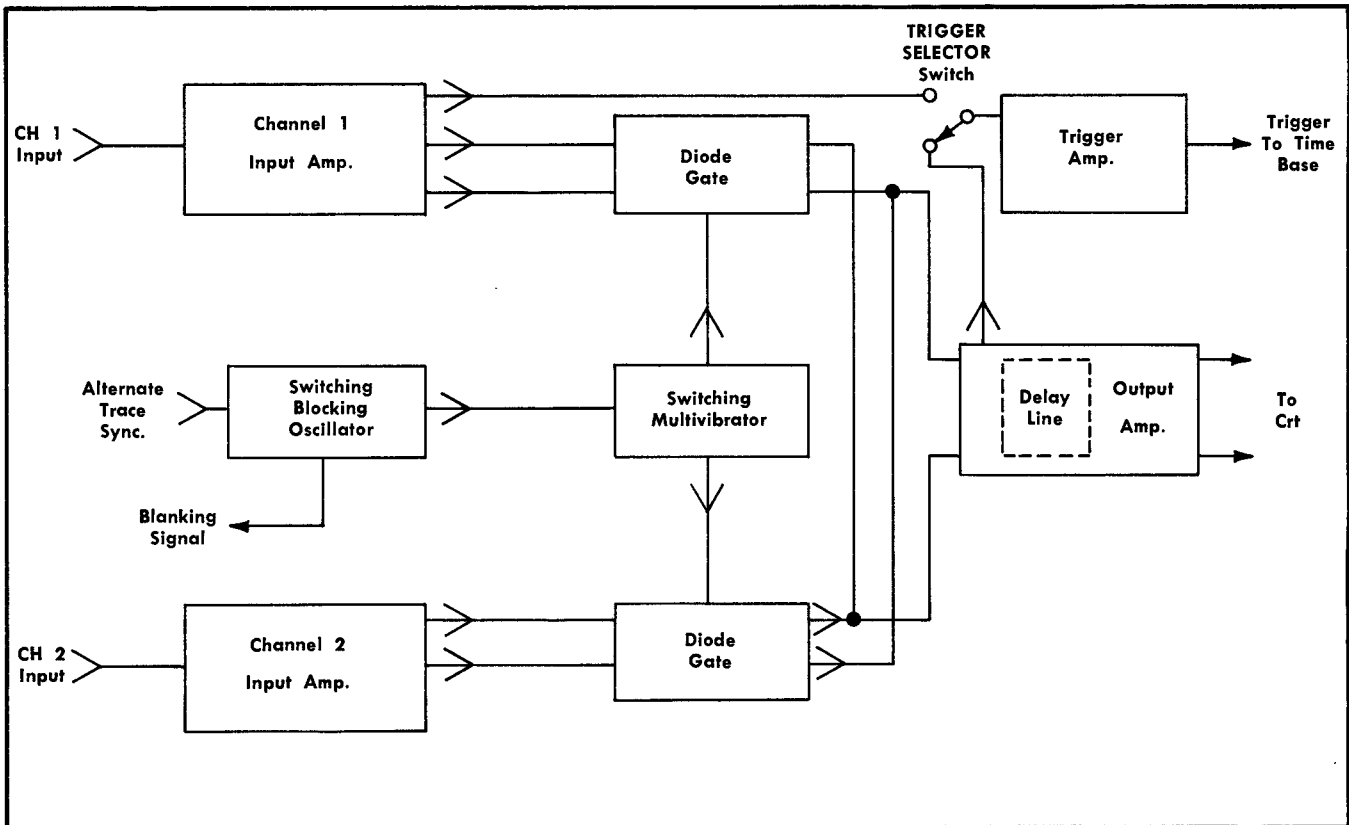

Fig. 3-1. Block diagram of Type 3A6.

Circuit Description — Type 3A6

Switching Circuit

The switching circuit consists of two diode gates, a switching multivibrator, a switching blocking oscillator, and a blanking emitter follower.

Each diode gate consists of two series diodes and two shunt diodes. In order that a signal can pass through the diode gates to the bases of Q304 and Q314 in the output amplifier, the series diodes must be forward biased, and the shunt diodes must be back biased.

In the CH 1, CH 2, and ADDED positions of the MODE switch, the switching multivibrator is inoperative (i.e. neither transistor is conducting). In the ALTER and CHOP positions of the MODE switch, the switching multivibrator operates as a bistable multivibrator. In this case, the multivibrator is switched by the blocking oscillator. The blocking oscillator operates as either a "triggered" oscillator in the ALTER mode or an "astable" (free running) oscillator in the CHOP mode.

When the MODE switch is in the CH 1 position, collector current of Q134 and Q144 flows through the series diodes. The MODE switch SW290 reverse-biases Q285 and holds it in the "off" state. Q275 is also "off", and holds the junction of D156 and D157 at -2.1 volts. Since the dc level in the signal output from Channel 1 input amplifier is -2.3 volts, the shunt diodes are back biased. The cathodes of the Channel 2 shunt diodes, D256 and D257 are held at about -4.2 volts by Q285. D256 and D257 are conducting and hold the Channel 2 output at about -3.5 volts. Since the output of the diode gates is at about -3 volts, D255 and D258 are back biased. With D255 and D258 cut off, the Channel 2 signal is not transmitted to the output amplifier. In addition, since D256 and D257 are conducting, they form a low-impedance path for any signals coming to the diode gate from the Channel 2 input amplifier.

When the MODE switch is in the CH 2 position, the conditions of the diode gate are reversed. The Channel 2 shunt diodes D256 and D257 and the Channel 1 series diodes D155 and D158 are back biased. Therefore, the signal from the Channel 2 input amplifier passes through D255 and D258 to the output amplifier and the Channel 1 signal is blocked by D155 and D158.

When the MODE switch is in either the ALTER or CHOP positions, Q275 and Q285 operate as a bistable multivibrator. Positive pulses from the switching blocking oscillator, Q260, pass through D278 or D288 to the collector of the "off" state transistor. This pulse is transmitted by either C277 or C287 to the base of the "on" transistor, turning it "off". The collector of this "off" transistor moves toward the -12.2 -volt supply, turning the other transistor "on" because of the coupling through either C277 or C287. Resistive dividers R277-R286 and R276-R287 set the levels at the transistor bases. The voltage levels allow switching action to occur when a pulse is received from the blocking oscillator.

Operation of the diode gates in ALTER and CHOP is the same as described in the CH 1 and CH 2 positions of the MODE switch. However, the multivibrator is free to switch states when it receives a trigger signal from the blocking oscillator, and thus operate the diode gates and transmit a signal to the output amplifier from Channel 1 and Channel 2 alternately. Also, in the ALTER and CHOP positions of the

MODE switch, R292 is bypassed and the collector loads, R278 and R288, of the multivibrator transistors are connected to the -12.2 -volt supply.

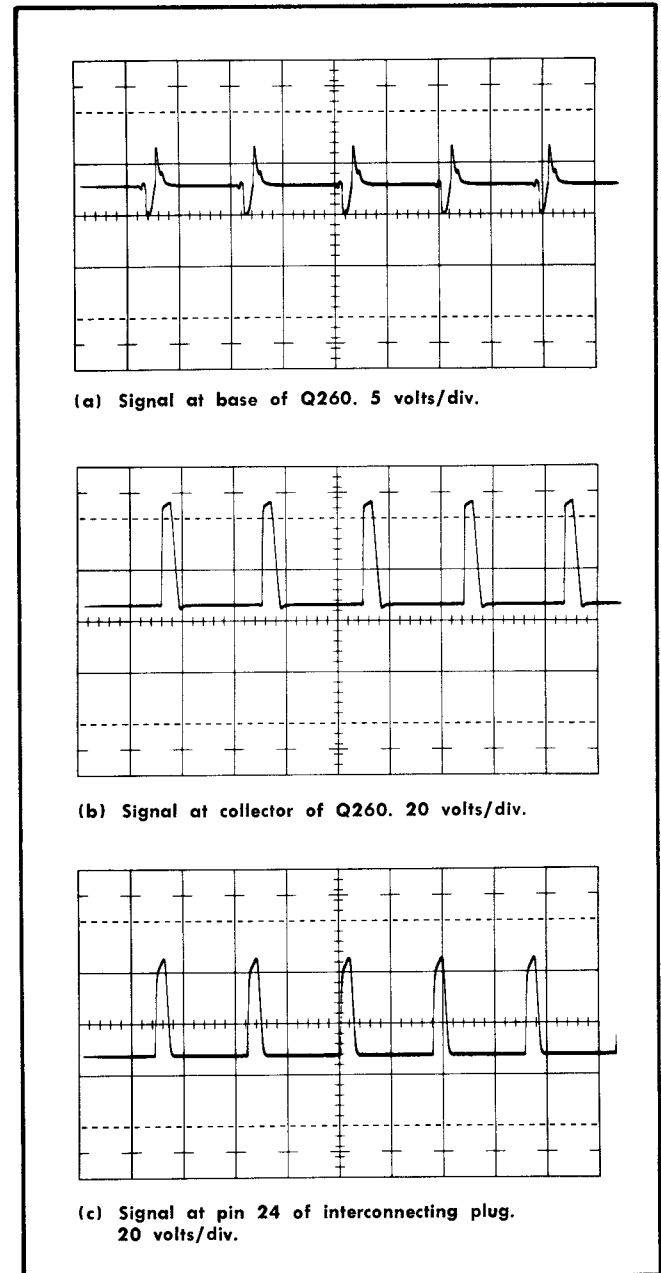

Fig. 3-2. Signals in blocking oscillator circuit. Test oscilloscope ac coupled at sweep rate of $2 \mu\text{sec}/\text{division}$.

In the CHOP and ALTER positions of the MODE switch, Q260 (switching blocking oscillator) is energized and supplies trigger pulses to the switching multivibrator. In the ALTER mode, the emitter of Q260 is connected to the -12.2 -volt supply through R261. The collector is connected to the -100 -volt supply through the collector winding of blocking oscillator transformer T263. When a positive pulse is fed from the time-base plug-in unit through terminal 3 of the interconnecting plug, the emitter voltage rises. The transistor conducts, drawing current through the collector winding of

blocking oscillator transformer T263, driving Q260 further into conduction. A normal blocking-oscillator cycle occurs, with the backswing cutting the transistor off. The transistor is biased so it does not turn on again until another sync pulse is received.

In the CHOP position of the MODE switch, the emitter of Q260 is connected to ground through R262. Normal free-running blocking oscillator action occurs. The base is forward biased since it is connected to the -12.2 -volt supply. Therefore the blocking oscillator is automatically triggered and free runs at about a 300 kc rate. Fig. 3-2 shows the blocking oscillator waveforms with the MODE switch in the CHOP position.

The positive output pulses produced by Q260 in the ALTER or CHOP position of the MODE switch are coupled to the switching multivibrator through D263 and C271. These positive pulses forward bias diode D278 or D288 to switch the multivibrator. Q260 also provides the blanking pulse to blank out the chopping transient. The emitter follower Q263 provides a fast trailing edge on the blanking pulse. Q263 is biased into operation only during the trailing edge of the blanking pulse.

When the MODE switch is in the ADDED position, current is supplied to the output amplifier through R293 and R294, holding the series diodes in both diode gates in conduction. Since the multivibrator transistors are both near cut off, the shunt diodes are back biased and thus inoperative. The signal from both Channel 1 and 2 is allowed to pass to the Output Amplifier and algebraically add or subtract depending on their polarity.

Output Amplifier

The output of the diode gate passes to the bases of Q304 and Q314. These transistors are connected as a common-emitter push-pull amplifier. The feedback networks from collector to base of Q304 and Q314 form an amplifier with low input and output impedance. R300-C300, R303-C303, R305-C305 and R307-C307 boost the gain at high frequencies to compensate for the losses in the delay line. R308 and R318 add to the low output impedance of the amplifier and match the stage to the delay line. However, the output impedance of the stage tends to increase at high frequencies. R309 and C309 are added to the circuit to compensate for this by effectively lowering the output impedance as frequency increases.

The delay line has a characteristic impedance of about 186Ω . Signal delay through the cable is 260 nsec. The output of the delay line is coupled to the Q324-Q334, V344A-V344B stage. Since this stage has a low input impedance, R320, R321, R330, R331, C321 and C331 are added so that the delay line is terminated in its characteristic impedance.

The T-coils in the plate circuits of V344A and V344B provide high-frequency peaking. The signal from the plates of V344A and V344B are coupled directly to the control grids of the cathode followers V363A and V363B. These cathode followers drive the transistors Q364 and Q374 which in turn drive the output tubes V384 and V394. The feedback from the output stage to the bases of Q364 and Q374 reduces

the gain variation due to different tube transconductance (gm). This also increases the linear scan range of the output stage. Diodes D365 and D375 limit the voltage on the collectors of Q364-Q374 and therefore limit the dissipation of the transistors if one or the other of the output tubes (V384 or V394) cut off.

OUTPUT DC LEVEL Adjustment. This adjustment (R346) sets the operating level of the last few stages of the instrument so that the average output voltage to the deflection plates of the crt is $+190$ volts.

CALIB Adjustment. This adjustment (R389) adjusts the gain of the last stage by changing the cathode degeneration of V384 and V394. This permits the gain of the plug-in unit to be matched to the deflection factor of the indicator unit cathode-ray tube.

Trigger Amplifiers

The Type 3A6 contains a trigger amplifier to supply an internal trigger pulse to the time-base circuitry. The TRIGGER switch selects the triggering signal from either of two similar trigger pickoff amplifiers: Q164-Q174 in Channel 1 or Q404-Q414 in the Output Amplifier. Each of these trigger pickoff amplifiers is an emitter-coupled difference amplifier with double-ended input and single-ended output. The triggering signal from either pickoff amplifier circuit is obtained prior to signal delay. This allows the internal trigger signal to trigger the time-base circuitry before the vertical signal reaches the crt deflection plates.

The Channel 1 trigger signal is obtained from the Q133-Q143 stage. The CHAN 1 TRIG DC LEVEL control R171 provides a means of adjusting the dc level of the Channel 1 trigger signal.

The composite trigger signal is obtained from the Q304-Q314 stage. The COMP TRIG DC LEVEL control R412 provides a means of adjusting the dc level of the composite trigger signal. The dc level of the composite trigger signal is affected by the setting of the POSITION controls. Therefore, the COMP TRIG DC LEVEL adjustment is set with the POSITION controls at midrange.

The TRIGGER switch SW420 selects the triggering signal from the output of either Q164 (Channel 1 only) or Q414 (composite). The output of the unused trigger pickoff amplifier is connected to the -12.2 supply through R420.

The trigger output amplifier is a low input impedance amplifier having a transimpedance of $15 \text{ k} (\Delta 3 \text{ volt output} \div \Delta 2 \text{ milliamp input})$. D425 prevents Q444 from saturating by limiting the positive input signal. D424 provides a path to the -12.2 supply when D425 limits the positive input signal. Diode D423 limits the negative voltage excursion of the input and prevents overshoot when a large trigger signal is present.

The Zener diode D447 drops the voltage level of the trigger amplifier output signal about 15 volts so that the output to pin 11 of the interconnecting plug is nominally zero volts with a no-signal trace positioned to crt center.

SECTION 4

MAINTENANCE

PREVENTIVE MAINTENANCE

Recalibration

To insure accurate measurements, check the calibration of this instrument after each 500 hours of operation or every six months if used intermittently. Complete calibration instructions are given in Section 5.

Visual Inspection

The Type 3A6 should be inspected occasionally for such defects as broken connections, broken or damaged ceramic strips, improperly seated tubes or transistors and heat-damaged parts.

The remedy for most visible defects is obvious; however, particular care must be taken if heat-damaged parts are located. Overheating is usually only a symptom of trouble. For this reason, it is essential to determine the actual cause of overheating before the heat-damaged parts are relaced; otherwise, the damage may be repeated.

Cleaning

The Type 3A6 should be cleaned as often as operating conditions require. Accumulation of dirt in the instrument can cause overheating and component breakdown. Dirt on components acts as an insulating blanket and prevents efficient heat dissipation. It also provides a conduction path for electricity.

To clean the interior of the Type 3A6, blow off the accumulated dust with dry, low-pressure air. Remove any dirt which remains with a soft paint brush or a cloth dampened with a mild detergent and water solution. A cotton-tipped applicator is useful for cleaning in narrow spaces or for cleaning ceramic terminal strips.

The front panel of the Type 3A6 can be cleaned with a soft cloth dampened with a mild solution of water and detergent. Do not use abrasive cleaners.

CAUTION

Avoid the use of chemical cleaning agents which might damage the plastics used in this unit. Avoid chemicals such as benzene, toluene, xylene, acetone or similar solvents.

CORRECTIVE MAINTENANCE

Soldering

Ceramic Terminal Strips. Solder used on the ceramic terminal strips should contain about 3% silver. Ordinary tin lead solder can be used occasionally. Use a 40- to 75-watt soldering iron with a $\frac{1}{8}$ " wide chisel-shaped tip. However, if ordinary solder is used repeatedly or if excessive heat is

applied, the solder-to-ceramic bond can be broken.

Solder containing 3% silver is usually available locally or it can be purchased from Tektronix in one pound rolls; order by Tektronix part number 251-514.

The following precautions should be observed when soldering ceramic terminal strips:

1. Use a hot iron for a short time. Apply only enough heat to make the solder flow freely.
2. Maintain a clean, properly tinned tip.
3. Avoid putting pressure on the ceramic terminal strip.
4. Do not attempt to fill the terminal-strip notch with solder; use only enough solder to cover the wires adequately.

Metal Terminals. When soldering metal terminals (e.g., interconnecting plug pins, switch terminals, potentiometers, etc.), ordinary 60/40 solder can be used. The soldering iron should have a 40- to 75-watt rating with a $\frac{1}{8}$ " wide chisel-shaped tip.

Observe the following precautions when soldering metal terminals.

1. Apply only enough heat to make the solder flow freely.
2. If a wire extends beyond the solder joint, clip the excess close to the joint.
3. Apply only enough solder to form a solid connection. Excess solder may impair the function of the part.

Component Replacement

Certain parts in the instrument are easier to replace if a definite procedure is followed. The procedures for replacing these parts are outlined in the following paragraphs.

Many electrical components are mounted in a particular manner to reduce or control stray capacitance. Duplicate the original location and mounting when replacing components. When selecting replacement parts, remember that the physical nature of a component can affect its performance at high frequencies. After repair, check the instrument calibration.

NOTE

Turn off the indicator unit power before replacing any components.

Standard Parts

All electrical and mechanical part replacements for the Type 3A6 can be obtained through your local Tektronix Field Office or representative. However, since many of the electronic components are standard parts, they can generally be obtained locally in less time than is required to

Maintenance — Type 3A6

order them from the factory. Before purchasing replacement parts, consult the Parts List for values, tolerances and ratings required.

Special Parts

In addition to the standard electronic components, some special parts are used in the production of the Type 3A6. These parts are manufactured or selected by Tektronix to meet specific performance requirements, or are manufactured for Tektronix in accordance with our specifications. Most of the mechanical parts used in this instrument have been manufactured by Tektronix. Order all of these special parts directly from your Tektronix Field Office or representative.

Ceramic Terminal Strip Replacement

A complete ceramic terminal strip assembly is shown in Fig. 4-1. Replacement strips (including studs) and spacers are supplied under separate part numbers. The old spacers may be reused unless they are damaged.

After the damaged strip has been removed, place the undamaged spacers in the chassis holes. Then, carefully press the studs into the spacers until they are completely seated. If necessary, use a soft mallet and tap lightly, directly over the stud area of the strip.

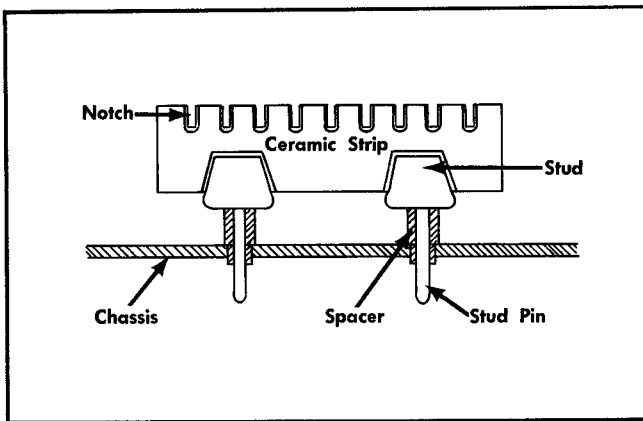

Fig. 4-1. Ceramic terminal strip assembly.

Tubes and Transistors

Do not replace tubes or transistors unless they are actually defective. If tubes or transistors are removed during routine maintenance, return them to their original sockets.

Static tube- or transistor-testers are not recommended for locating a defective tube or transistor. These testers often indicate a defective component when it is operating satisfactorily in a circuit, or may fail to indicate a characteristic which affects circuit performance. Since dynamic testers check operation under simulated circuit conditions, they provide a better check of component operation. However, the best overall test of tube or transistor performance is to substitute a new component or one which has been previously checked.

If a tube or transistor performs satisfactorily, do not replace it. Unnecessary replacement of components may re-

quire recalibration of the instrument. If tubes or transistors are replaced, check the operation of the unit.

Rotary Switches

Individual wafers or mechanical parts of rotary switches are normally not replaced. If a switch is defective, replace the entire assembly. Replacement switches can be ordered either wired or unwired; refer to the Parts List for part numbers.

TROUBLESHOOTING

Introduction

The following information is provided to facilitate troubleshooting of the Type 3A6 if trouble develops. During troubleshooting, information contained in this section of the manual should be used along with information obtained from other sections (e.g., Schematics, Operating Instructions, etc.).

Troubleshooting Aids

Schematic Diagrams. Circuit diagrams are given on pull-out pages in Section 6. The circuit numbers for each electronic component in this unit along with important voltages are shown on these diagrams.

Switch wafers shown on the diagrams are coded to indicate the position of the wafer in the complete switch assembly. The number portion of the code refers to the wafer number counting from the front or mounting end of the switch toward the rear. The letters 'F' and 'R' indicate whether the front or rear of the wafer is used to perform the particular switching function.

Wiring Color-Code. All insulated wire used in the Type 3A6 is color-coded to facilitate circuit tracing. The widest color stripe identifies the first color of the code. The regulated voltages supplied by the indicator unit are identified by the following code: white background color indicates positive voltage; tan, negative voltage.

+300 volts.....	Orange-black-brown on white
+125 volts.....	Brown-red-brown on white
-12.2 volts.....	Brown-red-black on tan
-100 volts.....	Brown-black-brown on tan

The heater wiring is indicated by a white background with a blue first stripe. The remainder of the wiring in the Type 3A6 is color-coded to facilitate point-to-point circuit tracing.

Resistor Color-Code. Some stable metal-film resistors are used in this instrument. These resistors can be identified by their gray body color. If a metal-film resistor has a value indicated by three significant figures and a multiplier, it will be color-coded according to the EIA standard. If it has a value indicated by four significant figures and a multiplier, the value will be printed on the body of the resistor. For example, a 333 k resistor will be color-coded, but a 333.5 k resistor will have its value printed on the resistor body. The color coding sequence is shown in Fig. 4-2 and Table 4-1.

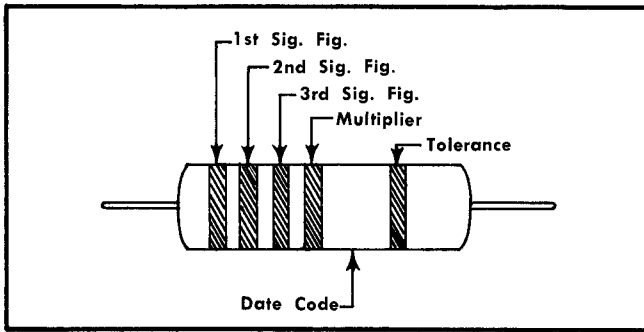

Fig. 4-2. Color coding of metal-film resistors.

Composition resistors are color coded according to the EIA standard resistor color code.

TABLE 4-1
Color Code Sequence

Color	1st Sig. Fig.	2nd Sig. Fig.	3rd Sig. Fig.	Multiplier	(±) % Tolerance
Black	0	0	0	1	—
Brown	1	1	1	10	1
Red	2	2	2	100	2
Orange	3	3	3	1,000	—
Yellow	4	4	4	10,000	—
Green	5	5	5	100,000	0.50
Blue	6	6	6	1,000,000	0.25
Violet	7	7	7	10,000,000	0.10
Gray	8	8	8	100,000,000	0.05
White	9	9	9	1,000,000,000	—
Gold				0.1	5
Silver				0.01	—
No Color					10

Test Equipment

The following equipment will be useful in troubleshooting the Type 3A6.

1. Dynamic Transistor Tester
Purpose: To test transistors and diodes used in the Type 3A6.
Description: Tektronix Type 575 Transistor-Curve Tracer.
2. Dc Voltmeter
Purpose: To check operating voltages in the unit.
Description: 20,000 ohms/volt.
3. Test Oscilloscope
Purpose: To check circuit operation.
Description: Tektronix Type 561A with Type 3A75 and Type 2B67 plug-in units, or equivalent.

4. Flexible Plug-In Extension Cable

Purpose: Permits maximum accessibility to the Type 3A6 while operating the unit outside of the plug-in compartment.

Description: 30", 24-pin. Tektronix Part No. 012-066.

Check Front-Panel Controls

Before proceeding with extensive troubleshooting, check the front-panel control settings. In addition, check the front-panel screwdriver adjustments for proper adjustment. An incorrect control setting can produce an apparent trouble. If in doubt as to the proper setting of a control or adjustment, see "First-Time Operation" in Section 2.

Check Indicator Unit and Time Base

The indicator unit and time base can be checked for proper operation by substituting another amplifier plug-in unit — preferably another Type 3A6 — which is known to be operating properly. If the trouble persists after substitution, the indicator unit or time base is defective.

Trouble Location

If the Type 3A6 is definitely at fault, make a careful operational check of the unit. Note the effect that each front-panel control has on the symptom. Also check the effect of the calibration adjustments. The normal or abnormal operation of each control or adjustment may help isolate the trouble to the defective circuit.

After the trouble has been isolated to a particular circuit, perform a complete visual check of that circuit. Many troubles can be found most easily by visual means. If a visual check fails to detect the cause of trouble, check the tubes or transistors used in the circuit by replacing them with tubes or transistors known to be good (or check with a dynamic tester). Most of the troubles which occur result from tube or transistor failures. Be sure to return any tubes or transistors found to be good to their original sockets.

The following procedure may aid in location of the defective component after the tubes or transistors have been found to be good.

1. Isolate the trouble to a portion of the circuit if possible.
2. Recheck the reaction of the front-panel controls and calibration adjustments on the affected circuit.
3. Check the voltages in the circuit. Typical operating voltages are given on the schematic diagrams.
4. Check waveforms in the circuit with a test oscilloscope.
5. Check the components in the circuit (i.e., check for faulty capacitors, off-tolerance resistors, etc.).

SECTION 5

CALIBRATION

Introduction

The Type 3A6 should be calibrated every 500 hours or every six months if used intermittently. If transistors, tubes or other components are replaced, the calibration of the repaired circuit should be checked.

The following procedure is arranged in a sequence which will allow the instrument to be calibrated with the least interaction of adjustments and reconnection of equipment. If desired, the steps may be performed out of sequence or a step may be performed individually. However, it may be necessary to refer to the preceding step(s) and/or preliminary procedure for additional setup information.

All calibration adjustments in this unit are shown in Fig. 5-1.

NOTE

This procedure is written to provide a performance check of the instrument along with complete calibration. Steps entitled 'Check' permit a check of an operational standard of the unit. 'Adjust' steps provide a check of performance and adjustment if necessary.

EQUIPMENT REQUIRED

The following equipment, or equivalent, is required for a complete calibration of the Type 3A6.

- (1) Calibrated 560-Series indicator unit. If the indicator unit does not contain a time base, use a Tektronix Type 3B1, 3B3 or 3B4 plug-in unit.
- (2) Dc voltmeter; 20,000 ohms/volt, 2% accuracy.
- (3) Square-wave generator; frequency, 100 cps to 300 kc. Risetime, 20 nanoseconds or less. Output amplitude, about 0.8 volts into 50 ohms. Tektronix Type 105 Square-Wave Generator recommended.
- (4) Input capacitance standardizer; 47 pf., BNC connectors. Tektronix Part No. 011-068.
- (5) Termination; 50 ohm, BNC connectors. Tektronix Part No. 011-049.
- (6) Attenuator; 50 ohm, 5XT, BNC connectors. Tektronix Part No. 011-060.
- (7) Cables; (two), 50 ohm, 42" long, BNC connectors. Tektronix Part No. 012-057.
- (8) BNC 'T' connector. Tektronix Part No. 103-030.
- (9) Screwdriver; non-metallic. Tektronix Part No. 003-000.
- (10) Alignment tool; non-metallic. Tektronix Part No. 003-301.

PRELIMINARY PROCEDURE

1. Remove both side panels from the indicator unit.

2. Insert the Type 3A6 in the left-hand plug-in compartment.

3. Insert the time-base unit in the right-hand plug-in compartment.

4. Preset the indicator unit front-panel controls as follows:

Calibrator	50 mVolts
------------	-----------

Adjust the remaining controls for a suitable display.

5. Preset the time-base controls as follows:

Mode	Norm.
------	-------

Time/Div.	1 mSec
-----------	--------

Triggering	
------------	--

Level	centered
-------	----------

Slope	+
-------	---

Coupling	Auto
----------	------

Source	Int.
--------	------

6. Preset the Type 3A6 controls (both channels where applicable) as follows:

POSITION	midrange
----------	----------

AC DC GND	GND
-----------	-----

VOLTS/DIV	.01
-----------	-----

VARIABLE	CALIB
----------	-------

MODE	CH 1
------	------

INV (CH 1) NORM	NORM
-----------------	------

TRIGGER	pushed in
---------	-----------

7. Connect the indicator unit to the correct line voltage and turn the POWER switch ON.

CALIBRATION PROCEDURE

1. Adjust Channel 1 and 2 Dc Balance

- a. **Check** — Rotate Channel 1 VARIABLE throughout its range. As the trace moves vertically, adjust the DC BAL control as follows:

- b. Turn the DC BAL control to bring the trace near graticule center.

- c. Turn the VARIABLE control fully counterclockwise and position the trace to the graticule centerline with the POSITION control.

- d. Return the VARIABLE control to the CALIB position. Measure the exact distance the trace is displaced above or below the centerline.

- e. Adjust the DC BAL control to move the trace exactly half this distance (measure in step 1e) past the graticule centerline.

NOTE

Both DC BAL controls are the dual-range or coarse-fine type. To use this type of control, turn the control slightly past the desired point of ad-

Calibration — Type 3A6

justment (coarse adjust). Then, reverse the direction of rotation and use the fine adjustment (about 30° range) to establish balance.

f. Check the balance by rotating the VARIABLE control throughout its range. If the amplifier is not properly balanced, repeat steps 1d, 1e, and 1f.

g. Set the MODE switch to CH 2 and repeat the above procedure for Channel 2.

2. Check Chopped Mode Operation

a. Set the MODE switch to CHOP and position the two traces about 2 major divisions apart.

b. Set the Type 3B1 Time/Div. switch for a sweep rate of 5 μ Sec.

c. Check the display for one to two trace segments per major graticule division.

3. Check Alternate Mode Operation

a. Set the MODE switch to ALTER.

b. Set the Type 3B1 Time/Div. switch for a sweep rate of .1 Sec.

c. Check for trace alternation between Channel 1 and 2.

d. Return the MODE switch to CH 1.

4. Adjust Output Dc Level

a. Position the trace to the graticule centerline.

b. Measure the dc voltage from each of the crt vertical deflection plate connections (on left side of crt) to ground.

c. **Check** — Average voltage of the crt plate should be +190 volts; for example, one plate at +185 and the other at +195 volts. If not, adjust according to the following step.

d. Adjust OUTPUT DC LEVEL R346 for an average voltage of +190 volts.

5. Adjust Channel 1 Trigger Dc Level

a. Pull the TRIGGER switch out to the CHANNEL 1 ONLY position.

b. Connect the dc voltmeter to Pin 12 of the Horizontal plug-in interconnecting plug.

c. **Check** — Voltage reading should be zero. If not, adjust as follows:

d. Adjust CHAN 1 TRIG DC LEVEL R171 for zero volt reading on the meter.

e. There is some interaction between the CHAN 1 TRIG DC LEVEL control and the Channel 1 DC BAL control. Recheck step 1 if an adjustment is made in step 5d.

6. Adjust Composite Trigger Dc Level

a. Push the TRIGGER switch in.

b. Position the trace to the graticule centerline.

c. **Check** — Voltage reading should be zero volts. If not, adjust as follows:

d. Adjust COMP TRIG DC LEVEL R412 for zero volt reading on the meter.

e. Disconnect the voltmeter.

7. Adjust Channel 1 10 Mv Gain

a. Set the Channel 1 AC DC GND switch to DC.

b. Make sure the VARIABLE control is set to CALIB (UNCAL light off).

c. Connect the 50-millivolt signal from the indicator unit Cal Out connector to Channel 1 input.

d. Turn the CALIB control to midrange.

e. **Check** — Check for 5 major divisions of deflection. If incorrect, adjust as follows:

f. Adjust 10 MV GAIN R149 for 5 major divisions of vertical deflection.

8. Adjust Channel 1 20 Mv Gain

a. Set the Channel 1 VOLTS/DIV switch to .02.

b. Set the indicator unit calibrator to .1 volts.

c. **Check** — Check for 5 major divisions of deflection. If incorrect, adjust as follows:

d. Adjust 20 MV GAIN R147 for 5 major divisions of vertical deflection.

9. Adjust Channel 2 10 Mv Gain

a. Connect the calibrator output to both inputs using the BNC 'T' connector and a 50-ohm cable.

b. Set the Channel 2 AC DC GND switch to DC.

c. Set both VOLTS/DIV switches to .01.

d. Make sure both VARIABLE controls are set to CALIB (UNCAL light off).

e. Set the calibrator for 50 mVolts output.

f. Position both traces to the center of the graticule.

g. Set the MODE switch to ADDED and the INV (CH 1) NORM switch to INV.

h. **Check** — Check for a straight line indicating identical gain in Channels 1 and 2. If square-wave signal is seen, adjust as follows:

i. Adjust 10 MV GAIN R249 for complete cancellation of the Channel 1 signal indicated by a straight line.

10. Adjust Channel 2 20 Mv Gain

a. Set the calibrator to .1 Volts.

b. Set both VOLTS/DIV switches to .02.

c. **Check** — Check for a straight line indicating identical gain in Channel 1 and 2. If square-wave signal is seen, adjust as follows:

d. Adjust 20 MV GAIN R247 for a straight line.

11. Check Both VARIABLE Controls

- a. Set both VOLTS/DIV switches to .01 and both VARIABLE controls to CALIB.
- b. Set the INV (CH 1) NORM switch to NORM.
- c. Connect a 50 mVolts signal from the calibrator to the input of both channels.
- d. Set the MODE switch to CH 1. The display should be 5 divisions high.
- e. Turn the Channel 1 VARIABLE control fully counter-clockwise. The display should be reduced to 2 major divisions or less.
- f. Check that the Channel 1 UNCAL light is on.
- g. Return the Channel 1 VARIABLE to CALIB; the UNCAL light should go out.
- h. Set the MODE switch to CH 2. Repeat steps 11e, f and g to check the Channel 2 VARIABLE control.
- i. Disconnect the calibrator signal from the input connectors.

12. Check Grid Current

- a. Set both VOLTS/DIV switches to .02 and VARIABLE controls to CALIB.
- b. Set both AC DC GND switches to GND.

- c. Set the MODE switch to CH 1.

d. Note Channel 1 trace vertical position in the GND position and then set the Channel 1 AC DC GND switch to AC. Trace shift should not exceed 2 minor divisions (4 mm).

- e. Set the MODE switch to CH 2 and repeat step 12d for Channel 2.

13. Adjust Channel 1 and 2 Input Capacitance

- a. Connect the square-wave generator to the Channel 1 input through the 5X T and the capacitance standardizer.
- b. Set the generator output frequency to 1 kc.
- c. Set the Channel 1 VOLTS/DIV switch to .01.
- d. Set the Channel 1 AC DC GND switch to DC.
- e. Set the MODE switch to CH 1 and the INV (CH 1) NORM switch to NORM.
- f. Set the generator output amplitude for 4 major divisions of deflection.
- g. Set the time-base Time/Div. switch to .2.
- h. Adjust C111 for optimum flat-top waveform.
- i. Set the Channel 1 VOLTS/DIV switch to .02.
- j. Adjust C112 for optimum flat-top waveform.

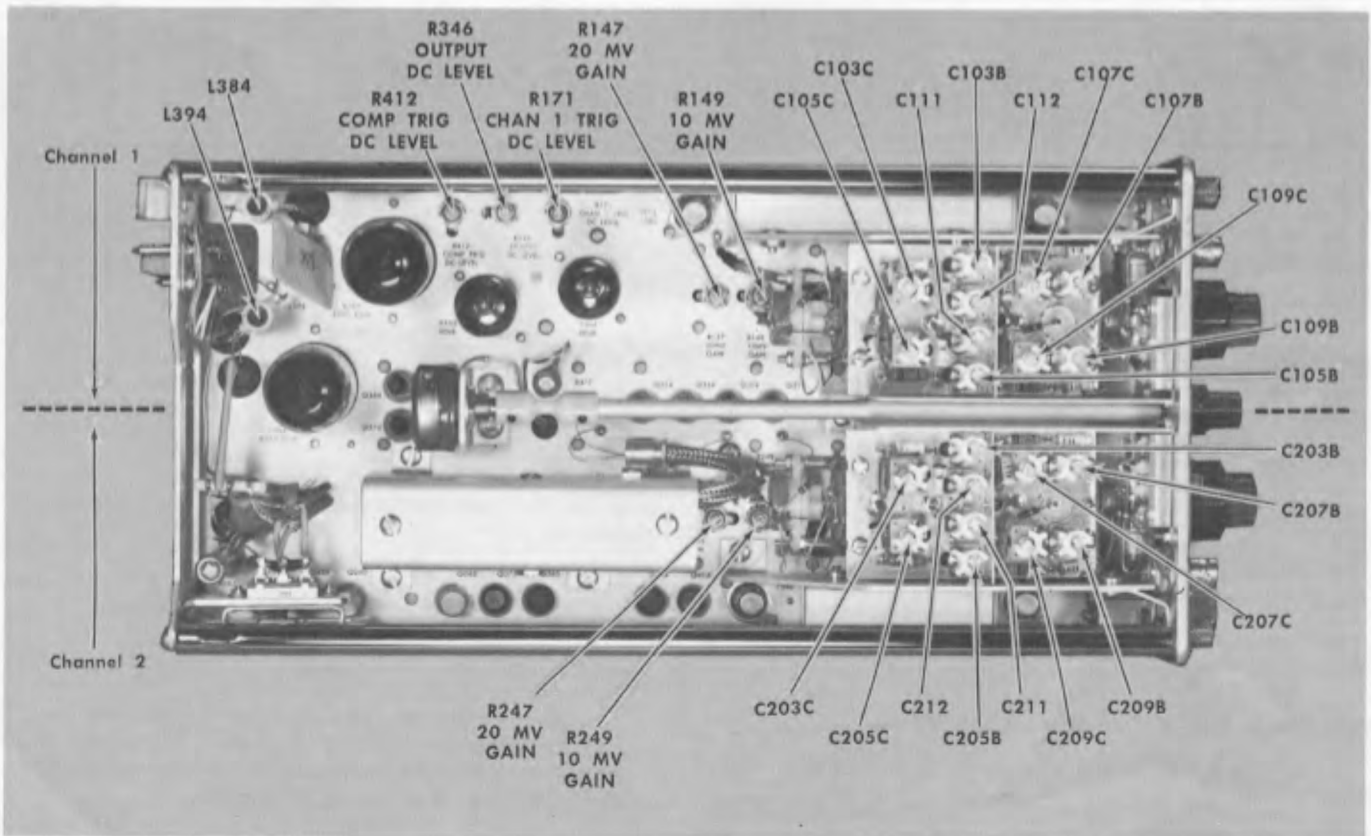

Fig. 5-1. Calibration adjustments in Type 3A6 (left-side view).

Calibration — Type 3A6

k. Remove the signal from Channel 1 input and connect to Channel 2 input.

l. Set the MODE switch to CH 2.

m. Set the Channel 2 VOLTS/DIV switch to .01.

n. Set the Channel 2 AC DC GND switch to DC.

o. Adjust C211 for optimum flat-top waveform.

p. Set the Channel 2 VOLTS/DIV switch to .02.

q. Adjust C212 for optimum flat-top waveform.

14. Adjust Channel 1 and 2 VOLTS/DIV Compensation

a. Use the same test setup used in step 13.

b. Adjust the Channel 2 VOLTS/DIV compensation as shown in Table 5-1. Readjust the generator output with each setting of the VOLTS/DIV switch to provide 4 divisions of deflection (except in the 2 position where the maximum deflection will be about 1 division).

c. Connect the generator signal to Channel 1 input.

d. Set the MODE switch to CH 1 and adjust the Channel 1 VOLTS/DIV compensation as shown in Table 5-1.

TABLE 5-1

VOLTS/DIV Switch Setting	Channel 1		Channel 2	
	Adjust for Optimum		Adjust for Optimum	
	Square Corner	Flat Top	Square Corner	Flat Top
.05	C103C	C103B	C203C	C203B
.1	C105C	C105B	C205C	C205B
.2	C107C	C107B	C207C	C207B
2	C109C	C109B	C209C	C209B

15. Adjust High-Frequency Compensation

a. Set the Channel 1 VOLTS/DIV switch to .01 and the VARIABLE to CALIB.

b. Set the MODE switch to CH 1.

c. Set the time-base Time/Div. switch to .5 μ Sec.

d. Connect the generator signal to Channel 1 input through a 5XT attenuator and a 50-ohm termination.

e. Set the generator output frequency to 300 kc.

f. Set the generator output amplitude for a 4-centimeter display.

g. Adjust L384 and L394 for optimum square corner on the waveform with minimum overshoot.

h. Disconnect the generator from the Channel 1 input connector.

16. Check VOLTS/DIV Attenuation Ratios

a. Set the indicator unit Calibrator for 50 mVolts output.

b. Connect the Cal Out connector to the Channel 1 input with 50-ohm cable.

c. Set the time-base Time/Div. switch to 5 mSec.

d. Set the MODE switch to CH 1.

e. Check for proper vertical deflection in each position of the Channel 1 VOLTS/DIV switch using Table 5-2 as a guide.

f. Set the MODE switch to CH 2 and connect the Cal Out signal to Channel 2 input. Check the attenuation of Channel 2 VOLTS/DIV switch using Table 5-2 as a guide.

g. Disconnect the calibrator signal from the input connector.

NOTE

Since the indicator unit calibrator accuracy is $\pm 3\%$ and the rated accuracy of the input attenuators is $\pm 3\%$, the maximum allowable deviation from the indicated deflection is $\pm 6\%$.

TABLE 5-2

VOLTS/DIV Switch Setting	Calibrator Output (peak-to-peak)	Vertical Deflection in Divisions
.01	50 mVolts	5
.02	.1 Volts	5
.05	.2 Volts	4
.1	.5 Volts	5
.2	1 Volts	5
.5	2 Volts	4
1	5 Volts	5
2	10 Volts	5
5	20 Volts	4
10	50 Volts	5

17. Check Channel Isolation

a. Set the Channel 1 VOLTS/DIV switch to 10 and the Channel 2 VOLTS/DIV switch to .01.

b. Set the MODE switch to ALTER.

c. Set the generator output frequency for 100 kc.

d. Connect the generator to the Channel 1 input with a 50-ohm cable.

e. Set the generator output amplitude for 5 divisions of deflection.

f. The Channel 2 deflection should be 1 mm or less, indicating channel isolation of 50,000:1 or better.

NOTE

The attenuators are not shielded adequately unless the side panels are in place. Therefore, to obtain an accurate measurement of channel isolation, replace the left side panel.

SECTION 6

PARTS LIST AND SCHEMATICS

PARTS ORDERING INFORMATION

Replacement parts are available from or through your local Tektronix Field Office.

Changes to Tektronix instruments are sometimes made to accommodate improved components as they become available, and to give you the benefit of the latest circuit improvements developed in our engineering department. It is therefore important, when ordering parts, to include the following information in your order: Part number including any suffix, instrument type, serial number, and modification number if applicable.

If a part you have ordered has been replaced with a new or improved part, your local Tektronix Field Office will contact you concerning any change in part number.

ABBREVIATIONS AND SYMBOLS

a or amp	amperes	mm	millimeter
BHS	binding head steel	meg or M	megohms or mega (10 ⁶)
C	carbon	met.	metal
cer	ceramic	μ	micro, or 10 ⁻⁶
cm	centimeter	n	nano, or 10 ⁻⁹
comp	composition	Ω	ohm
cps	cycles per second	OD	outside diameter
crt	cathode-ray tube	OHS	oval head steel
CSK	counter sunk	p	pico, or 10 ⁻¹²
dia	diameter	PHS	pan head steel
div	division	piv	peak inverse voltage
EMC	electrolytic, metal cased	plstc	plastic
EMT	electrolytic, metal tubular	PMC	paper, metal cased
ext	external	poly	polystyrene
f	farad	Prec	precision
F & I	focus and intensity	PT	paper tubular
FHS	flat head steel	PTM	paper or plastic, tubular, molded
Fil HS	fillister head steel	RHS	round head steel
g or G	giga, or 10 ⁹	rms	root mean square
Ge	germanium	sec	second
GMV	guaranteed minimum value	Si	silicon
h	henry	S/N	serial number
hex	hexagonal	t or T	tera, or 10 ¹²
HHS	hex head steel	TD	toroid
HSS	hex socket steel	THS	truss head steel
HV	high voltage	tub.	tubular
ID	inside diameter	v or V	volt
incd	incandescent	Var	variable
int	internal	w	watt
k or K	kilohms or kilo (10 ³)	w/	with
kc	kilocycle	w/o	without
m	milli, or 10 ⁻³	WW	wire-wound
mc	megacycle		

SPECIAL NOTES AND SYMBOLS

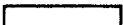
X000	Part first added at this serial number.
000X	Part removed after this serial number.
*000-000	Asterisk preceding Tektronix Part Number indicates manufactured by or for Tektronix, or reworked or checked components.
Use 000-000	Part number indicated is direct replacement.
	Internal screwdriver adjustment.
	Front-panel adjustment or connector.

EXPLODED VIEW

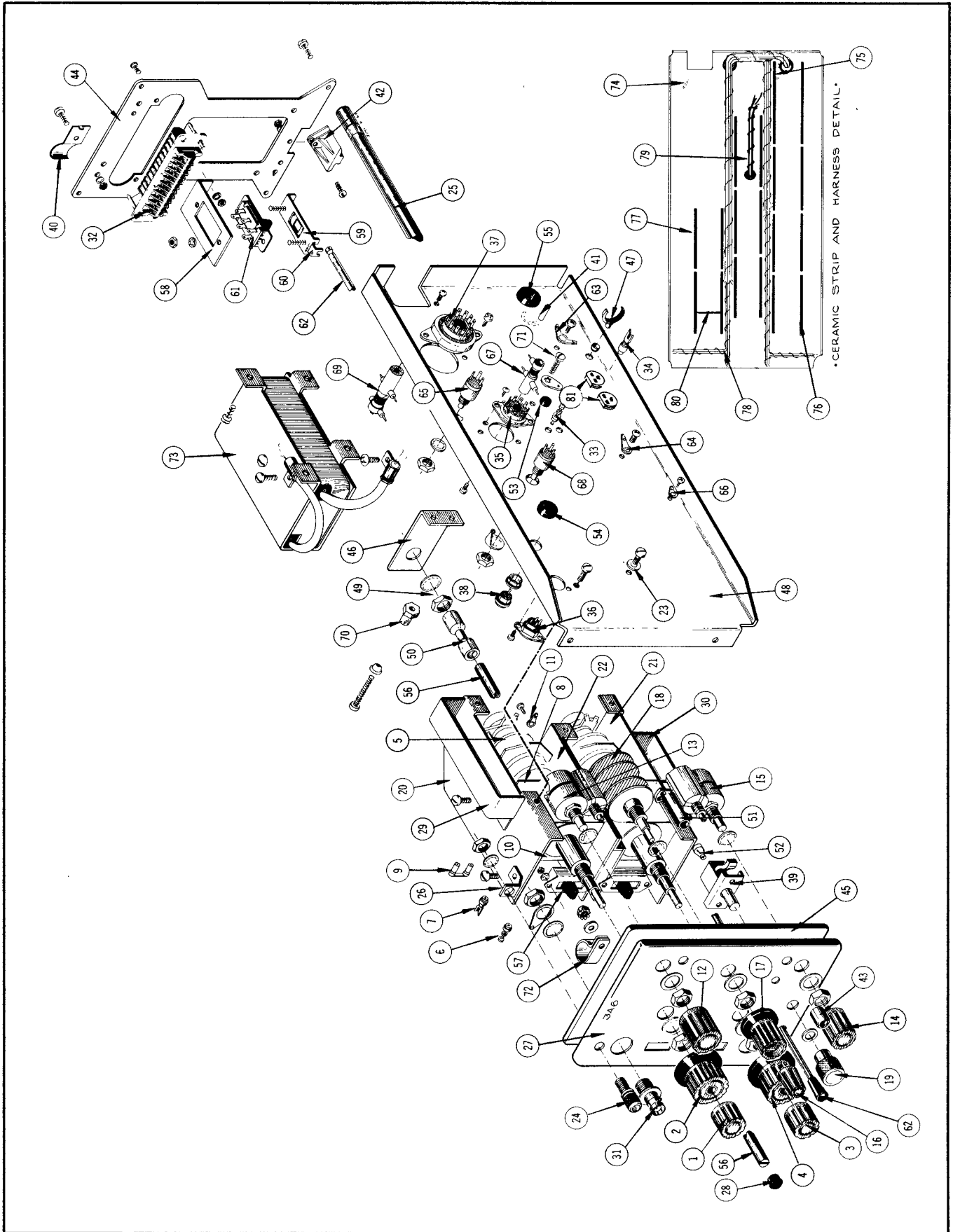

EXPLODED VIEW

REF. NO.	PART NO.	SERIAL/MODEL NO.		QTY.	DESCRIPTION
		EFF.	DISC.		
1	366-0031-00			1	KNOB, small red—VARIABLE (CH 1)
	- - - - -			-	Includes:
	213-0004-00			1	SCREW, set, 6-32 x 3/16 inch HSS
2	366-0160-00			1	KNOB, large charcoal—VOLTS/DIV (CH 1)
	- - - - -			-	Includes:
	213-0004-00			1	SCREW, set, 6-32 x 3/16 HSS
3	366-0031-00			1	KNOB, small red—VARIABLE (CH 2)
	- - - - -			-	Includes:
	213-0004-00			1	SCREW, set, 6-32 x 3/16 HSS
4	366-0160-00			1	KNOB, large charcoal—VOLTS/DIV (CH 2)
	- - - - -			-	Includes:
	213-0004-00			1	SCREW, set, 6-32 x 3/16 HSS
5	262-0653-00			2	SWITCH, wired—VOLTS/DIV (CH1 and 2)
	- - - - -			-	Each Includes:
	260-0607-00			1	SWITCH, unwired—VOLTS/DIV (CH 1 and 2)
6	131-0182-00			1	CONNECTOR, terminal, feed thru
	- - - - -			-	Mounting Hardware: (not included)
	358-0136-00			1	BUSHING, teflon
7	131-0344-00			8	CONNECTOR, terminal, feed thru
	- - - - -			-	Mounting Hardware For Each: (not included)
	358-0241-00			1	BUSHING, teflon
8	337-0680-00			1	SHIELD, attenuator
	- - - - -			-	Mounting Hardware: (not included w/switch assembly)
	211-0007-00	X730		1	SCREW, 4-40 x 3/16 inch BHS
	211-0008-00	X730		1	SCREW, 4-40 x 1/4 inch BHS
	210-0004-00	X730		2	LOCKWASHER, internal, #4
	210-0586-00	X730		2	NUT, keps, 4-40 x 1/4 inch
9	214-0456-00			10	FASTENER, press
10	441-0564-00			1	CHASSIS, attenuator
	- - - - -			-	Mounting Hardware: (not included)
	210-0004-00			4	LOCKWASHER, internal, #4
	210-0406-00			4	NUT, hex, 4-40 x 3/16 inch
	211-0007-00			4	SCREW, 4-40 x 3/16 inch BHS
11	210-0227-00	100	1788	1	LUG, solder, SE #6
	210-0201-00	1789	1949X	1	LUG, solder, SE #4
	- - - - -			-	Mounting Hardware: (not included)
	210-0406-00			1	NUT, hex, 4-40 x 3/16 inch
	211-0007-00			1	SCREW, 4-40 x 3/16 inch BHS
	- - - - -			-	Mounting Hardware For Each Switch: (not included)
	210-0012-00			1	LOCKWASHER, internal, 3/8 x 1/2 inch
	210-0413-00			1	NUT, hex, 3/8-32 x 1/2 inch
12	366-0148-00			1	KNOB, small charcoal—POSITION (CH 1)
	- - - - -			-	Includes:
	213-0004-00			1	SCREW, set, 6-32 x 3/16 inch HSS
13	- - - - -			-	Mounting Hardware For Pot:
	210-0012-00			1	LOCKWASHER, internal, 3/8 x 1/2 inch
	210-0413-00			1	NUT, hex, 3/8-32 x 1/2 inch
	210-0840-00			1	WASHER, .390 ID x 9/16 inch OD
14	366-0148-00			1	KNOB, small charcoal—POSITION (CH 2)
	- - - - -			-	Includes:
	213-0004-00			1	SCREW, set, 6-32 x 3/16 inch HSS

EXPLODED VIEW (Cont'd)

REF. NO.	PART NO.	SERIAL/MODEL NO.		QTY.	DESCRIPTION
		EFF.	DISC.		
15	210-0012-00 210-0413-00 210-0840-00			1 1 1	Mounting Hardware For Pot: LOCKWASHER, internal, 3/8 x 1/2 inch NUT, hex, 3/8-32 x 1/2 inch WASHER, .390 ID x 9/16 inch OD
16	366-0189-00			1	KNOB, small red—INV (CH 1) NORM
	213-0004-00			-	Includes:
17	366-0175-00			1	SCREW, set, 6-32 x 3/16 inch HSS
	213-0004-00			1	KNOB, medium charcoal—MODE
	260-0442-00			-	Includes:
18	210-0012-00			1	SCREW, set, 6-32 x 3/16 inch HSS
	210-0413-00			1	SWITCH, unwired—MODE
19	366-0109-00			-	Mounting Hardware: (not included)
	213-0004-00			1	LOCKWASHER, internal, 3/8 x 1/2 inch
	337-0675-00			1	NUT, hex, 3/8-32 x 1/2 inch
20	211-0503-00			1	KNOB, plug-in securing
	337-0676-00			-	Includes:
21	211-0503-00			1	SCREW, set, 6-32 x 3/16 inch HSS
	337-0510-00			1	SHIELD, top
22	210-0803-00			-	Mounting Hardware: (not included)
	211-0507-00			3	SCREW, 6-32 x 5/16 inch BHS
23	210-0803-00			1	SHIELD, bottom
	211-0507-00			-	Mounting Hardware: (not included)
24	129-0051-00			3	SCREW, 6-32 x 5/16 inch BHS
	200-0182-00			1	SHIELD, middle
	210-0011-00			-	Mounting Hardware: (not included)
	210-0455-00			1	WASHER, 6L x 3/8 inch
	355-0507-00			2	SCREW, 6-32 x 5/16 inch BHS
25	384-0615-00			2	POST, binding, assembly
	212-0044-00			-	Each Includes:
	406-0845-00			1	CAP, binding post
	333-0808-00			1	LOCKWASHER, internal, 1/4 inch
	358-0178-00			1	NUT, hex, 1/4-28 x 3/8 inch
	358-0216-00			1	STEM, binding post adapter
	337-0507-00			4	ROD, spacer, 12 1/4 inches long
	211-0503-00			-	Mounting Hardware For Each: (not included)
26	337-0506-00			1	SCREW, 8-32 x 1/2 inch RHS, phillips
27	211-0503-00			2	BRACKET, ground
28	337-0507-00			1	PANEL, front
	211-0503-00	100	3519	1	BUSHING, panel, charcoal
	211-0503-00	3520		1	BUSHING, panel, gray
29	211-0503-00			1	SHIELD, top box
	211-0503-00			-	Mounting Hardware: (not included)
30	211-0503-00			2	SCREW, 6-32 x 3/16 inch BHS
	211-0503-00			1	SHIELD, bottom box
	211-0503-00			-	Mounting Hardware: (not included)
	211-0503-00			2	SCREW, 6-32 x 3/16 inch BHS

EXPLODED VIEW (Cont'd)

REF. NO.	PART NO.	SERIAL/MODEL NO.		QTY.	DESCRIPTION
		EFF.	DISC.		
31	131-0126-00			2	CONNECTOR, coaxial, chassis mounted, BNC
	210-0241-00			2	LUG, ground
32	131-0149-00			1	CONNECTOR, chassis mounted, 24 contact
	- - - - -			-	Mounting Hardware: (not included)
	210-0004-00			1	LOCKWASHER, internal, #4
	210-0201-00			1	LUG, solder, SE #4
	210-0406-00			2	NUT, hex, 4-40 x 3/16 inch
	211-0008-00			2	SCREW, 4-40 x 1/4 inch BHS
33	131-0182-00			7	CONNECTOR, terminal, feed thru
	- - - - -			-	Mounting Hardware For Each: (not included)
	358-0136-00			1	BUSHING, teflon
34	131-0235-00			1	CONNECTOR, terminal
	- - - - -			-	Mounting Hardware: (not included)
	358-0136-00			1	BUSHING, teflon
35	136-0015-00			2	SOCKET, STM9G
	- - - - -			-	Mounting Hardware For Each: (not included)
	213-0044-00			2	SCREW, thread forming, 5-32 x 3/16 inch PHS
36	136-0101-00			4	SOCKET, 5 pin
	- - - - -			-	Mounting Hardware For Each: (not included)
	213-0055-00			2	SCREW, thread forming, 2-56 x 3/16 inch PHS
37	136-0174-00			2	SOCKET, 9 pin
	- - - - -			-	Mounting Hardware For Each: (not included)
	213-0044-00			2	SCREW, thread forming, 5-32 x 3/16 inch PHS
38	136-0181-00			22	SOCKET, transistor, 3 pin
	- - - - -			-	Mounting Hardware For Each: (not included)
	354-0234-00			1	RING, mounting
39	214-0052-00			1	FASTENER, right, with stop
	- - - - -			-	Mounting Hardware (not included)
	210-0004-00			2	LOCKWASHER, internal, #4
	210-0406-00			2	NUT, hex, 4-40 x 3/16 inch
40	214-0276-00			2	SPRING, ground
	- - - - -			-	Mounting Hardware For Each: (not included)
	210-0006-00			1	LOCKWASHER, internal, #6
	210-0407-00			1	NUT, hex, 6-32 x 1/4 inch
	211-0504-00			1	SCREW, 6-32 x 1/4 inch BHS
41	343-0089-00			2	CLAMP, cable, delrin
42	351-0037-00			1	GUIDE, delrin
	- - - - -			-	Mounting Hardware: (not included)
	210-0004-00			1	LOCKWASHER, internal, #4
	210-0406-00			1	NUT, hex, 4-40 x 3/16 inch
	211-0013-00			1	SCREW, 4-40 x 3/8 inch RHS
43	358-0075-00			2	BUSHING, 1/4-32 x .295 inch long
44	387-0647-00			1	PLATE, rear
45	387-0660-00			1	PLATE, front

EXPLODED VIEW (Cont'd)

REF. NO.	PART NO.	SERIAL/MODEL NO.		QTY.	DESCRIPTION
		DISC.	EFF.		
46	406-814			1	BRACKET, pot
	- - - -			-	Mounting Hardware: (not included)
	211-507			2	SCREW, 6-32 x 5/16 inch BHS
47	426-121			1	HOLDER, toroid, nylon
	- - - -			-	Mounting Hardware: (not included)
	361-007			1	SPACER, nylon
48	441-544			1	CHASSIS
	- - - -			-	Mounting Hardware: (not included)
	211-507			2	SCREW, 6-32 x 5/16 inch BHS
	211-538			3	SCREW, 6-32 x 5/16 inch FHS, phillips
49	- - - -			-	Mounting Hardware For Pot:
	210-413			1	NUT, hex, 3/8-32 x 1/2 inch
	210-840			1	WASHER, .390 ID x 7/16 inch OD
50	376-011			1	COUPLING, insulating, nylon
	- - - -			-	Includes:
	213-048			2	SCREW, set, 4-40 x 1/8 inch HSS
51	352-067			2	HOLDER, single
	- - - -			-	Mounting Hardware For Each: (not included)
	210-406			1	NUT, hex, 4-40 x 3/16 inch
	211-031			1	SCREW, 4-40 x 1 inch FHS
52	378-541			1	FILTER, lens, neon light
53	348-002			1	GROMMET, rubber, 1/4 inch
54	348-004			5	GROMMET, rubber, 3/8 inch
55	348-005			1	GROMMET, rubber, 1/2 inch
56	384-246			1	ROD, extension
57	260-448			2	SWITCH, unwired — AC-DC-GND (CH 1 and 2)
	- - - -			-	Mounting Hardware For Each: (not included)
	210-406			2	NUT, hex, 4-40 x 3/16 inch
58	406-800			1	BRACKET, switch, slide
	- - - -			-	Mounting Hardware: (not included)
	211-504			2	SCREW, 6-32 x 1/4 inch BHS
59	406-949			1	BRACKET, switch, slide
	- - - -			-	Mounting Hardware: (not included)
	210-004			2	LOCKWASHER, internal, #4
	210-406			2	NUT, hex, 4-40 x 3/16 inch
60	406-918			1	BRACKET, slide, switch, actuator
61	260-447			1	SWITCH, unwired — TRIGGER
62	384-304			1	ROD, extension, with knob
63	210-204			3	LUG, solder, DE #4
	- - - -			-	Mounting Hardware For Each: (not included)
	213-044			1	SCREW, thread cutting, 5-32 x 3/16 inch PHS, phillips
64	210-201			4	LUG, solder, SE #4
	- - - -			-	Mounting Hardware For Each: (not included)
	213-044			1	SCREW, thread cutting, 5-32 x 3/16 inch PHS, phillips

EXPLODED VIEW (Cont'd)

REF. NO.	PART NO.	SERIAL/MODEL NO.		QTY.	DESCRIPTION
		EFF.	DISC.		
65	- - - - -			-	Mounting Hardware For Miniature Pot:
	210-0583-00			1	NUT, hex, $\frac{1}{4}$ -32 x $\frac{5}{16}$ inch
	210-0940-00			1	WASHER, $\frac{1}{4}$ ID x $\frac{3}{8}$ inch OD
66	210-0259-00			6	LUG, solder, #2
	- - - - -			-	Mounting Hhardware For Each: (not included)
	213-0055-00			1	SCREW, thread forming, 2-32 x $\frac{3}{16}$ inch UHS
67	- - - - -			-	Mounting Hardware For Coil:
	213-0088-00			1	SCREW, thread forming, #4 x $\frac{1}{4}$ inch PHS
68	- - - - -			-	Mounting Hardware For Miniature Pot:
	210-0223-00			1	LUG, solder, $\frac{1}{4}$ inch hole
	210-0583-00			1	NUT, hex, $\frac{1}{4}$ -32 x $\frac{5}{16}$ inch
69	- - - - -			-	Mounting Hardware For Coil:
	213-0054-00			1	SCREW, thread cutting, 6-32 x $\frac{5}{16}$ inch PHS
70	- - - - -			-	Mounting Hardware For 10 Watt Resistor:
	210-0203-00			1	LUG, solder, SE #6 long
	210-0478-00			1	NUT, hex, $\frac{5}{16}$ x $2\frac{1}{32}$ inch long
	210-0601-00			1	EYELET
	211-0538-00			1	SCREW, 6-32 x $\frac{5}{16}$ inch FHS 100° CSK
	211-0553-00			1	SCREW, 6-32 x 1- $\frac{1}{2}$ inches RHS
71	- - - - -			-	Mounting Hardware For 5 Watt Resistor:
	210-0478-00			1	NUT, hex, $\frac{5}{16}$ x $2\frac{1}{32}$ inch long
	211-0507-00			1	SCREW, 6-32 x $\frac{5}{16}$ inch BHS
	211-0544-00			1	SCREW, 6-32 x $\frac{3}{4}$ inch THS
72	343-0006-00			2	CLAMP, cable, $\frac{1}{2}$ inch plastic
	- - - - -			-	Mounting hardware For Each: (not included)
	210-0457-00			1	NUT, keps, 6-32 x $\frac{5}{16}$ inch
	210-0803-00			1	WASHER, 6L x $\frac{3}{8}$ inch
	211-0538-00			1	SCREW, 6-32 x $\frac{5}{16}$ inch FHS
73	119-0033-00			1	DELAY LINE ASSEMBLY
	- - - - -			-	Includes:
	131-0272-00			2	CONNECTOR, cable
	200-0568-00			1	COVER, delay line
	210-0457-00			1	NUT, keps, 6-32 x $\frac{5}{16}$ inch
	211-0507-00			2	SCREW, 6-32 x $\frac{5}{16}$ inch BHS
	211-0503-00			1	SCREW, 6-32 x $\frac{3}{16}$ inch, PHS
	211-0529-00			1	SCREW, 6-32 x 1- $\frac{1}{4}$ inches BHS
	343-0108-00			1	CLAMP, delay line
	- - - - -			-	Mounting Hardware: (not included)
	211-0504-00			4	SCREW, 6-32 x $\frac{1}{4}$ inch BHS
	213-0104-00			1	SCREW, thread forming, #6 x $\frac{3}{8}$ inch THS
74	124-0087-00			1	STRIP, ceramic, $\frac{3}{4}$ inch x 3 notches
	- - - - -			-	Includes:
	355-0046-00			1	STUD, nylon
	- - - - -			-	Mounting Hardware: (not included)
	361-0007-00			1	SPACER, nylon

ELECTRICAL PARTS

Values are fixed unless marked Variable.

Ckt. No.	Tektronix Part No.	Description	S/N Range
Bulbs			
B113	150-027	Neon, NE-23	
B150	Use 150-025	Neon, NE-2E	100-5779
B150	150-0030-00	Neon, NE-2V	5780-up
B213	150-027	Neon, NE-23	
B250	Use 150-025	Neon, NE-2E	100-5779
B250	150-0030-00	Neon, NE-2V	5780-up

Capacitors

Tolerance $\pm 20\%$ unless otherwise indicated.

Tolerance of all electrolytic capacitors as follows (with exceptions):

$$3 \text{ V} - 50 \text{ V} = -10\%, +250\%$$

$$51 \text{ V} - 350 \text{ V} = -10\%, +100\%$$

$$351 \text{ V} - 450 \text{ V} = -10\%, +50\%$$

C101	*285-609	0.1 μf	PTM	600 v	10%	
C102	281-0626-00	3.3 pf	Cer	500 v	5%	X1950-up
C103A	281-501	4.7 pf	Cer	500 v	± 1 pf	
C103B	281-103	1.8-13 pf	Air	Var		
C103C	281-103	1.8-13 pf	Air	Var		
C103D	281-541	6.8 pf	Cer	500 v	10%	
C105A	281-501	4.7 pf	Cer	500 v	± 1 pf	
C105B	281-103	1.8-13 pf	Air	Var		
C105C	281-101	1.5-9.1 pf	Air	Var		
C105E	281-503	8 pf	Cer	500 v	± 0.5 pf	
C107A	281-509	15 pf	Cer	500 v	10%	
C107B	281-103	1.8-13 pf	Air	Var		
C107C	281-101	1.5-9.1 pf	Air	Var		
C107E	281-513	27 pf	Cer	500 v		
C109A	281-509	15 pf	Cer	500 v	10%	
C109B	281-103	1.8-13 pf	Air	Var		
C109C	281-101	1.5-9.1 pf	Air	Var		
C109E	283-541	500 pf	Mica	500 v	10%	
C110	281-509	15 pf	Cer	500 v	10%	
C111	281-103	1.8-13 pf	Air	Var		
C112	281-101	1.5-9.1 pf	Air	Var		
C113	283-068	0.01 μf	Cer	500 v		
C114	281-500	2.2 pf	Cer	500 v	± 0.5 pf	
C115	283-057	0.1 μf	Cer	200 v		
C121	283-0004-00	0.02 μf	Cer	150 v		X11820-up
C123	283-003	0.01 μf	Cer	150 v		100-11819
C123	283-0017-00	1 μf	Cer	3 v		11820-up
C125	283-003	0.01 μf	Cer	150 v		

Parts List — Type 3A6

Capacitors (Cont'd)

Ckt. No.	Tektronix Part No.		Description			S/N Range
C132	283-0059-00	1 μ f	Cer		25 v	X1650-up
C137	281-549	68 pf	Cer		500 v	10%
C149	281-523	100 pf	Cer		350 v	X240-up
C172	283-003	0.01 μ f	Cer		150 v	
C201	*285-609	0.1 μ f	PTM		600 v	10%
C202	281-0626-00	3.3 pf	Cer		500 v	5%
C203A	281-501	4.7 pf	Cer		500 v	± 1 pf
C203B	281-103	1.8-13 pf	Air	Var		
C203C	281-103	1.8-13 pf	Air	Var		
C203D	281-541	6.8 pf	Cer		500 v	10%
C205A	281-501	4.7 pf	Cer		500 v	± 1 pf
C205B	281-103	1.8-13 pf	Air	Var		
C205C	281-101	1.5-9.1 pf	Air	Var		
C205E	281-503	8 pf	Cer		500 v	± 0.5 pf
C207A	281-509	15 pf	Cer		500 v	10%
C207B	281-103	1.8-13 pf	Air	Var		
C207C	281-101	1.5-9.1 pf	Air	Var		
C207E	281-513	27 pf	Cer		500 v	
C209A	281-509	15 pf	Cer		500 v	10%
C209B	281-103	1.8-13 pf	Air	Var		
C209C	281-101	1.5-9.1 pf	Air	Var		
C209E	283-541	500 pf	Mica		500 v	10%
C210	281-509	15 pf	Cer		500 v	10%
C211	281-103	1.8-13 pf	Air	Var		
C212	281-101	1.5-9.1 pf	Air	Var		
C213	283-068	0.01 μ f	Cer		500 v	
C214	281-500	2.2 pf	Cer		500 v	± 0.5 pf
C215	283-057	0.1 μ f	Cer		200 v	
C221	283-0004-00	0.02 μ f	Cer		150 v	X11820-up
C223	283-003	0.01 μ f	Cer		150 v	100-11819
C223	283-0017-00	1 μ f	Cer		3 v	11820-up
C225	283-003	0.01 μ f	Cer		150 v	
C232	283-0059-00	1 μ f	Cer		25 v	X1650-up
C237	281-549	68 pf	Cer		500 v	10%
C249	281-523	100 pf	Cer		350 v	X240-up
C260	Use 281-518	47 pf	Cer		500 v	100-6299
C260	281-0523-00	100 pf	Cer		350 v	6300-up
C262	283-051	0.0033 μ f	Cer		100 v	
C263	283-003	0.01 μ f	Cer		150 v	
C265	283-057	0.1 μ f	Cer		200 v	
C269	283-003	0.01 μ f	Cer		150 v	
C271	281-513	27 pf	Cer		500 v	
C277	281-523	100 pf	Cer		350 v	
C287	281-523	100 pf	Cer		350 v	
C291	283-003	0.01 μ f	Cer		150 v	
C300	281-621	12 pf	Cer		500 v	1%
C300	281-0510-00	22 pf	Cer		500 v	6300-up
C303	281-622	47 pf	Cer		500 v	1%
C305	281-546	330 pf	Cer		500 v	10%
C307	281-575	39 pf	Cer		500 v	1%
C308	281-518	47 pf	Cer		500 v	10%
C309	281-542	18 pf	Cer		500 v	100-239X
C318	281-518	47 pf	Cer		500 v	X240-up
C321	281-564	24 pf	Cer		500 v	5%
C331	281-564	24 pf	Cer		500 v	5%
C345	283-000	0.001 μ f	Cer		500 v	
C350	281-0593-00	3.9 pf	Cer			10%
C364	283-003	0.01 μ f	Cer		150 v	X6300-7300X

Capacitors (Cont'd)

Ckt. No.	Tektronix Part No.		Description		S/N Range
C379	283-026	0.2 μ f	Cer	25 v	
C381	283-003	0.01 μ f	Cer	150 v	
C383	283-003	0.01 μ f	Cer	150 v	
C385	283-006	0.02 μ f	Cer	600 v	
C393	283-003	0.01 μ f	Cer	150 v	
C395	281-0605-00	200 pf	Cer	500 v	X1810-up
C407	281-501	4.7 pf	Cer	500 v	± 1 pf
C413	283-003	0.01 μ f	Cer	150 v	
C421	283-002	0.01 μ f	Cer	500 v	
C445	281-538	1 pf	Cer	500 v	100-2539X
C446	281-0537-00	0.68 pf	Cer	500 v	X6300-up
C447	283-003	0.01 μ f	Cer	150 v	
C451	283-003	0.01 μ f	Cer	150 v	
C452	283-026	0.2 μ f	Cer	25 v	
C453	290-134	22 μ f	EMT	15 v	
C457	283-004	0.02 μ f	Cer	150 v	
C458	283-003	0.01 μ f	Cer	150 v	
C461	283-059	1 μ f	Cer	25 v	
C462	283-003	0.01 μ f	Cer	150 v	

Diodes

D130	Use *152-0185-00	Silicon	Replaceable by 1N4152	
D131	Use *152-0185-00	Silicon	Replaceable by 1N4152	
D132	152-008	Germanium		100-6299
D132	*152-0185-00	Silicon	Replaceable by 1N4152	6300-up
D140	Use *152-0185-00	Silicon	Replaceable by 1N4152	
D155	152-141	Silicon	1N4152	100-6299
D155	152-0141-02	Silicon	1N4152	6300-up
D156	152-141	Silicon	1N4152	100-6299
D156	152-0141-02	Silicon	1N4152	6300-up
D157	152-141	Silicon	1N4152	100-6299
D157	152-0141-02	Silicon	1N4152	6300-up
D158	152-141	Silicon	1N4152	100-6299
D158	152-0141-02	Silicon	1N4152	6300-up
D230	Use *152-0185-00	Silicon	Replaceable by 1N4152	
D231	Use *152-0185-00	Silicon	Replaceable by 1N4152	
D232	152-008	Germanium		100-6299
D232	*152-0185-00	Silicon	Replaceable by 1N4152	6300-up
D240	Use *152-0185-00	Silicon	Replaceable by 1N4152	
D255	152-141	Silicon	1N4152	100-6299
D255	152-0141-02	Silicon	1N4152	6300-up
D256	152-141	Silicon	1N4152	100-6299
D256	152-0141-02	Silicon	1N4152	6300-up
D257	152-141	Silicon	1N4152	100-6299
D257	152-0141-02	Silicon	1N4152	6300-up
D258	152-141	Silicon	1N4152	100-6299
D258	152-0141-02	Silicon	1N4152	6300-up
D259	*152-0075-00	Germanium	Tek Spec	X4160-6299
D259	*152-0185-00	Silicon	Replaceable by 1N4152	6300-up
D260	Use *152-0185-00	Silicon	Replaceable by 1N4152	
D263	Use *152-0185-00	Silicon	Replaceable by 1N4152	

Diodes (Cont'd)

Ckt. No.	Tektronix Part No.	Description	S/N Range
D267	*152-061	Silicon	
D271	*152-0185-00	Silicon	
D278	Use *152-0185-00	Silicon	X6300-up
D288	Use *152-0185-00	Silicon	
D365	Use *152-0185-00	Silicon	
D375	Use *152-0185-00	Silicon	
D379	152-024	Zener	
D423	Use *152-0185-00	Silicon	
D424	Use *152-0185-00	Silicon	
D425	Use *152-0185-00	Silicon	
D447	152-031	Zener	
D447	152-0243-00	Zener	
D451	152-057	Zener	
D451	152-0264-00	Zener	
		Tek Spec	
		Replaceable by 1N4152	
		Replaceable by 1N4152	
		Replaceable by 1N4152	
		Replaceable by 1N4152	
		Replaceable by 1N4152	
		1N3024B 1 w, 15 v, 5%	
		Replaceable by 1N4152	
		Replaceable by 1N4152	
		Replaceable by 1N4152	
		1N718A 1/4 w, 15 v, 5%	100-5039
		1N965B 0.4 w, 15 v, 5%	5040-up
		1N3807B 1 w, 56 v, 5%	100-4495
		UZ756 3 w, 56 v, 5%	4496-up

Inductors

LR103	*108-283	0.13 μ h	(wound on a 43 Ω resistor)	
LR105	*108-286	0.17 μ h	(wound on a 36 Ω resistor)	
LR107	*108-283	0.13 μ h	(wound on a 43 Ω resistor)	
L160	*108-072	0.75 μ h		
L170	*108-072	0.75 μ h		
LR203	*108-283	0.13 μ h	(wound on a 43 Ω resistor)	
LR205	*108-286	0.17 μ h	(wound on a 36 Ω resistor)	
LR207	*108-283	0.13 μ h	(wound on a 43 Ω resistor)	
L319	*119-033	Delay Line Assy		
L344	*108-253	7.8 μ h		
L354	*108-253	7.8 μ h		
L379	*108-200	40 μ h		
L384	*114-151	35-50 μ h	Var	Core 276-511
L394	*114-151	35-50 μ h	Var	Core 276-511
L452	*108-016	29 μ h		
L462	108-245	3.9 μ h		

Transistors

Q133	151-107	2N967		100-6299
Q133	151-0220-00	2N4122		6300-up
Q134	Use 151-131	2N964		100-6299
Q134	151-0221-00	2N4258		6300-7300
Q134	151-0199-00	MPS-3640		7301-up
Q143	151-107	2N967		100-6299
Q143	151-0220-00	2N4122		6300-up
Q144	Use 151-131	2N964		100-6299
Q144	151-0221-00	2N4258		6300-7300
Q144	151-0199-00	MPS-3640		7301-up
Q164	151-076	2N2048		100-6299
Q164	151-0220-00	2N4122		6300-up
Q174	151-076	2N2048		100-6299
Q174	151-0220-00	2N4122		6300-up
Q233	151-107	2N967		100-6299
Q233	151-0220-00	2N4122		6300-up
Q234	Use 151-131	2N964		100-6299
Q234	151-0221-00	2N4258		6300-7300
Q234	151-0199-00	MPS-3640		7301-up
Q243	151-107	2N967		100-6299
Q243	151-0220-00	2N4122		6300-up

Transistors (cont)

Ckt. No.	Tektronix Part No.	Description	S/N Range
Q244	Use 151-131	2N964	100-6299
Q244	151-0221-00	2N4258	6300-7300
Q244	151-0199-00	MPS-3640	7301-up
Q260	151-063	2N2207	100-6299
Q260	*151-0228-00	Tek Spec	6300-up
Q263	151-063	2N2207	100-6299
Q263	*151-0228-00	Tek Spec	6300-up
Q275	151-076	2N2048	100-6299
Q275	151-0188-00	2N3906	6300-up
Q285	151-076	2N2048	100-6299
Q285	151-0188-00	2N3906	6300-up
Q304	151-107	2N967	100-6299
Q304	151-0221-00	2N4258	6300-7300
Q304	151-0199-00	MPS-3640	7301-up
Q314	151-107	2N967	100-6299
Q314	151-0221-00	2N4258	6300-7300
Q314	151-0199-00	MPS-3640	7301-up
Q324	151-107	2N967	100-6299
Q324	151-0221-00	2N4258	6300-7300
Q324	151-0199-00	MPS-3640	7301-up
Q334	151-107	2N967	100-6299
Q334	151-0221-00	2N4258	6300-7300
Q334	151-0199-00	MPS-3640	7301-up
Q364	151-107	2N967	100-6299
Q364	151-0164-00	2N3702	6300-up
Q374	151-107	2N967	100-6299
Q374	151-0164-00	2N3702	6300-up
Q404	151-076	2N2048	100-6299
Q404	151-0220-00	2N4122	6300-up
Q414	151-076	2N2048	100-6299
Q414	151-0220-00	2N4122	6300-up
Q433	151-107	2N967	100-6299
Q433	151-0220-00	2N4122	6300-up
Q444	*151-121	Selected from 2N3118	100-13079
Q444	*151-0124-00	Selected from 2N3119	13080-up

Resistors

Resistors are fixed, composition, $\pm 10\%$ unless otherwise indicated.

R101	302-100	10 Ω	$\frac{1}{2}$ w			
R103C	322-643	600 k	$\frac{1}{4}$ w	Prec	1%	100-3499
R103C	322-0643-01	600 k	$\frac{1}{4}$ w	Prec	$\frac{1}{2}\%$	3500-up
R103E	322-644	666.6 k	$\frac{1}{4}$ w	Prec	1%	100-3499
R103E	322-0644-01	666.6 k	$\frac{1}{4}$ w	Prec	$\frac{1}{2}\%$	3500-up
R105C	322-620	800 k	$\frac{1}{4}$ w	Prec	1%	100-3499
R105C	322-0620-01	800 k	$\frac{1}{4}$ w	Prec	$\frac{1}{2}\%$	3500-up
R105E	322-614	250 k	$\frac{1}{4}$ w	Prec	1%	100-3499
R105E	322-0614-01	250 k	$\frac{1}{4}$ w	Prec	$\frac{1}{2}\%$	3500-up
R107C	322-621	900 k	$\frac{1}{4}$ w	Prec	1%	100-3499
R107C	322-0621-01	900 k	$\frac{1}{4}$ w	Prec	$\frac{1}{2}\%$	3500-up
R107E	322-608	111 k	$\frac{1}{4}$ w	Prec	1%	100-3499
R107E	322-1389-01	111 k	$\frac{1}{4}$ w	Prec	$\frac{1}{2}\%$	3500-up
R109A	315-101	100 Ω	$\frac{1}{4}$ w		5%	
R109C	322-624	990 k	$\frac{1}{4}$ w	Prec	1%	100-3499
R109C	322-0624-01	990 k	$\frac{1}{4}$ w	Prec	$\frac{1}{2}\%$	3500-up

Parts List — Type 3A6

Resistors (Cont'd)

Ckt. No.	Tektronix Part No.	Description	S/N Range
R109D	315-510	51 Ω 1/4 w	5%
R109E	322-605	10.1 k 1/4 w	Prec 1%
R109E	322-1289-01	10.1 k 1/4 w	Prec 1/2% 100-3499
R109F	316-150	15 Ω 1/4 w	Prec 1/2% 3500-up
R110	315-470	47 Ω 1/4 w	5%
R111	322-481	1 meg 1/4 w	Prec 1%
R111	322-0481-01	1 meg 1/4 w	Prec 1/2% 100-3499
R113	315-105	1 meg 1/4 w	5% 3500-up
R114	316-101	100 Ω 1/4 w	
R115	302-221	220 Ω 1/2 w	
R116	301-562	5.6 k 1/2 w	5%
R119	311-321	2 x 500 k Var	CH 1 DC BAL
R120	316-335	3.3 meg 1/4 w	100-11819
R120	315-0105-00	1 meg 1/4 W	5% 11820-up
R121	302-274	270 k 1/2 w	100-11819
R121	315-0624-00	620 k 1/4 W	5% 11820-up
R123	316-182	1.8 k 1/4 w	100-11819
R123	315-0102-00	1 k 1/4 W	5% 11820-up
R124	316-101	100 Ω 1/4 w	
R125	316-101	100 Ω 1/4 w	
R126	301-562	5.6 k 1/2 w	5%
R131	316-0103-00	10 k 1/4 w	X1650-up
R132	316-0472-00	4.7 k 1/4 w	X1650-up
R133	301-431	430 Ω 1/2 w	5%
R134	315-391	390 Ω 1/4 w	5%
R135	322-224	2.1 k 1/4 w	Prec 1%
R137	316-470	47 Ω 1/4 w	
R138	315-391	390 Ω 1/4 w	5%
R139†	*311-319	375 Ω Var	CH 1 VARIABLE
R142	322-210	1.5 k 1/4 w	Prec 1%
R143	301-431	430 Ω 1/2 w	5%
R144	315-391	390 Ω 1/4 w	5%
R145	322-224	2.1 k 1/4 w	Prec 1%
R147	311-258	100 Ω Var	CH 1 20 MV GAIN
R148	316-680	68 Ω 1/4 w	
R149	311-258	100 Ω Var	CH 1 10 MV GAIN
R150	316-104	100 k 1/4 w	
R151	302-683	68 k 1/2 w	
R152	301-163	16 k 1/2 w	5%
R153	311-114	2 x 250 k Var	CH 1 POSITION
R154	302-683	68 k 1/2 w	
R160	316-221	220 Ω 1/4 w	
R164	315-622	6.2 k 1/4 w	5%
R167	322-617	47.7 Ω 1/4 w	Prec 1%
R170	316-221	220 Ω 1/4 w	
R171	311-448	20 k Var	CH 1 TRIG DC LEVEL
R172	316-333	33 k 1/4 w	
R174	315-622	6.2 k 1/4 w	5%
R201	302-100	10 Ω 1/2 w	
R203C	322-643	600 k 1/4 w	Prec 1% 100-3499
R203C	322-0643-01	600 k 1/4 w	Prec 1/2% 3500-up
R203E	322-644	666.6 k 1/4 w	Prec 1% 100-3499
R203E	322-0644-01	666.6 k 1/4 w	Prec 1/2% 3500-up

†Furnished as a unit with SW150

Resistors (Cont'd)

Ckt. No.	Tektronix Part No.		Description			S/N Range
R205C	322-620	800 k	1/4 w	Prec	1%	100-3499
R205C	322-0620-01	800 k	1/4 w	Prec	1/2%	3500-up
R205E	322-614	250 k	1/4 w	Prec	1%	100-3499
R205E	322-0614-01	250 k	1/4 w	Prec	1/2%	3500-up
R207C	322-621	900 k	1/4 w	Prec	1%	100-3499
R207C	322-0621-01	900 k	1/4 w	Prec	1/2%	3500-up
R207E	322-608	111 k	1/4 w	Prec	1%	100-3499
R207E	322-1389-01	111 k	1/4 w	Prec	1/2%	3500-up
R209A	315-101	100 Ω	1/4 w		5%	
R209C	322-624	990 k	1/4 w	Prec	1%	100-3499
R209C	322-0624-01	990 k	1/4 w	Prec	1/2%	3500-up
R209D	315-510	51 Ω	1/4 w		5%	
R209E	322-605	10.1 k	1/4 w	Prec	1%	100-3499
R209E	322-1289-01	10.1 k	1/4 w	Prec	1/2%	3500-up
R209F	316-150	15 Ω	1/4 w			
R210	315-470	47 Ω	1/4 w		5%	
R211	322-481	1 meg	1/4 w	Prec	1%	100-3499
R211	322-0481-01	1 meg	1/4 w	Prec	1/2%	3500-up
R213	315-105	1 meg	1/4 w		5%	
R214	316-101	100 Ω	1/4 w			
R215	302-221	220 Ω	1/2 w			
R216	301-562	5.6 k	1/2 w		5%	
R219	311-321	2 x 500 k		Var	CH 2 DC BAL	
R220	316-335	3.3 meg	1/4 w			100-11819
R220	315-0105-00	1 meg	1/4 W		5%	11820-up
R221	302-274	270 k	1/2 w			100-11819
R221	315-0624-00	620 k	1/4 W		5%	11820-up
R223	316-182	1.8 k	1/4 w			100-11819
R223	315-0102-00	1 k	1/4 W		5%	11820-up
R224	316-101	100 Ω	1/4 w			
R225	316-101	100 Ω	1/4 w			
R226	301-562	5.6 k	1/2 w		5%	
R231	316-0103-00	10 k	1/4 w			X1650-up
R232	316-0472-00	4.7 k	1/4 w			X1650-up
R233	301-431	430 Ω	1/2 w		5%	
R234	315-391	390 Ω	1/4 w		5%	
R235	322-224	2.1 k	1/4 w	Prec	1%	
R237	316-470	47 Ω	1/4 w			
R238	315-391	390 Ω	1/4 w		5%	
R239†	*311-319	375 Ω		Var	CH 2 VARIABLE	
R242	322-210	1.5 k	1/4 w	Prec	1%	
R243	301-431	430 Ω	1/2 w		5%	
R244	315-391	390 Ω	1/4 w		5%	
R245	322-224	2.1 k	1/4 w	Prec	1%	
R247	311-258	100 Ω		Var	CH 2 20 MV GAIN	
R248	316-680	68 Ω	1/4 w			
R249	311-258	100 Ω		Var	CH 2 10 MV GAIN	
R250	316-104	100 k	1/4 w			
R251	302-683	68 k	1/2 w			
R252	301-163	16 k	1/2 w		5%	
R253	311-114	2 x 250 k		Var	CH 2 POSITION	

†Furnished as a unit with SW250.

Resistors (Cont'd)

Ckt. No.	Tektronix Part No.		Description			S/N Range
R254	302-683	68 k	1/2 w			
R259	315-0183-00	18 k	1/4 w		5%	X4160-up
R260	316-102	1 k	1/4 w			100-6299
R260	316-0222-00	2.2 k	1/4 w			6300-up
R261	315-221	220 Ω	1/4 w		5%	
R262	315-682	6.8 k	1/4 w		5%	100-6299
R262	315-0622-00	6.2 k	1/4 w		5%	6300-up
R263	302-470	47 Ω	1/2 w			
R264	316-102	1 k	1/4 w			
R265	301-822	8.2 k	1/2 w		5%	
R266	316-331	330 Ω	1/4 w			
R267	303-822	8.2 k	1 w		5%	
R268	301-183	18 k	1/2 w		5%	
R269	316-101	100 Ω	1/4 w			
R271	302-103	10 k	1/2 w			
R273	301-202	2 k	1/2 w		5%	
R275	301-202	2 k	1/2 w		5%	
R276	322-287	9.53 k	1/4 w	Prec	1%	100-6299
R276	321-0297-00	12.1 k	1/8 w	Prec	1%	6300-up
R277	322-239	3.01 k	1/4 w	Prec	1%	
R278	322-155	402 Ω	1/4 w	Prec	1%	
R279	322-171	590 Ω	1/4 w	Prec	1%	
R285	301-202	2 k	1/2 w		5%	
R286	322-287	9.53 k	1/4 w	Prec	1%	100-6299
R286	321-0297-00	12.1 k	1/8 w	Prec	1%	6300-up
R287	322-239	3.01 k	1/4 w	Prec	1%	
R288	322-155	402 Ω	1/4 w	Prec	1%	
R289	322-171	590 Ω	1/4 w	Prec	1%	
R291	302-100	10 Ω	1/2 w			
R292	315-152	1.5 k	1/4 w		5%	
R293	322-207	1.4 k	1/4 w	Prec	1%	
R294	322-207	1.4 k	1/4 w	Prec	1%	
R300	322-201	1.21 k	1/4 w	Prec	1%	
R301	323-330	26.7 k	1/2 w	Prec	1%	
R302	322-123	187 Ω	1/4 w	Prec	1%	
R303	322-218	1.82 k	1/4 w	Prec	1%	
R304	322-123	187 Ω	1/4 w	Prec	1%	
R305	315-273	27 k	1/4 w		5%	
R306	322-130	221 Ω	1/4 w	Prec	1%	
R307	322-297	12.1 k	1/4 w	Prec	1%	
R308	322-089	82.5 Ω	1/4 w	Prec	1%	
R309	315-221	220 Ω	1/4 w		5%	101-239X
R311	323-330	26.7 k	1/2 w	Prec	1%	
R312	322-123	187 Ω	1/4 w	Prec	1%	
R314	322-123	187 Ω	1/4 w	Prec	1%	
R318	322-089	82.5 Ω	1/4 w	Prec	1%	
R320	322-051	33.2 Ω	1/4 w	Prec	1%	
R321	322-068	49.9 Ω	1/4 w	Prec	1%	
R322	322-251	4.02 k	1/4 w	Prec	1%	
R324	322-151	365 Ω	1/4 w	Prec	1%	
R326	322-147	332 Ω	1/4 w	Prec	1%	
R330	322-051	33.2 Ω	1/4 w	Prec	1%	
R331	322-068	49.9 Ω	1/4 w	Prec	1%	
R332	322-251	4.02 k	1/4 w	Prec	1%	
R334	322-151	365 Ω	1/4 w	Prec	1%	

Resistors (Cont'd)

Ckt. No.	Tektronix Part No.		Description		S/N Range
R341	316-470	47 Ω	1/4 w		
R344	322-200	1.18 k	1/4 w	Prec	1%
R345	316-101	100 Ω	1/4 w		
R346	311-323	1.5 k		Var	OUTPUT DC LEVEL
R347	322-154	392 Ω	1/4 w	Prec	1%
R348	305-682	6.8 k	2 w		5%
R349	322-209	1.47 k	1/4 w	Prec	1%
R350	315-0102-00	1 k	1/4 w		5% X6300-7300X
R351	316-470	47 Ω	1/4 w		
R354	322-200	1.18 k	1/4 w	Prec	1%
R357	322-154	392 Ω	1/4 w	Prec	1%
R358	305-682	6.8 k	2 w		5%
R361	316-470	47 Ω	1/4 w		
R364	308-077	1 k	3 w	WW	
R366	301-622	6.2 k	1/2 w		5%
R371	316-470	47 Ω	1/4 w		
R376	301-622	6.2 k	1/2 w		5%
R377	308-251	256 Ω	5 w	WW	5%
R380	316-470	47 Ω	1/4 w		
R381	316-470	47 Ω	1/4 w		
R383	302-274	270 k	1/2 w		
R384	*310-596	1.5 k	8 w	Prec	1%
R385	308-289	820 Ω	10 w	WW	5%
R386	322-097	100 Ω	1/4 w	Prec	1%
R387	303-620	62 Ω	1 w		5%
R389	311-383	150 Ω		Var	CALIB
R390	316-470	47 Ω	1/4 w		
R393	302-274	270 k	1/2 w		
R394	*310-596	1.5 k	8 w	Prec	1%
R396	322-097	100 Ω	1/4 w	Prec	1%
R399	322-101	110 Ω	1/4 w	Prec	1%
R401	315-471	470 Ω	1/4 w		5%
R405	322-218	1.82 k	1/4 w	Prec	1%
R407	322-147	332 Ω	1/4 w	Prec	1%
R411	315-471	470 Ω	1/4 w		5%
R412	311-448	20 k		Var	COMP TRIG DC LEVEL
R413	Use 316-123	12 k	1/4 w		
R415	322-218	1.82 k	1/4 w	Prec	1%
R420	302-470	47 Ω	1/2 w		
R421	316-101	100 Ω	1/4 w		
R423	323-322	22.1 k	1/2 w	Prec	1%
R425	302-684	680 k	1/2 w		
R426	315-0820-00	82 Ω	1/4 w		5% X6300-up
R433	315-272	2.7 k	1/4 w		5%
R444	308-112	6 k	5 w	WW	1% 100-2089
R444	308-0101-00	5.5 k	5 w	WW	5% 2090-up
R445	322-306	15 k	1/4 w	Prec	1%
R448	315-224	220 k	1/4 w		5% 100-2089
R448	304-0473-00	47 k	1 w		2090-up
R449	316-101	100 Ω	1/4 w		
R451	308-230	2.7 k	3 w	WW	5%
R454	307-034	8.2 Ω	1/2 w		
R455	307-034	8.2 Ω	1/2 w		
R457	316-270	27 Ω	1/4 w		
R461	316-220	22 Ω	1/4 w		

Parts List — 3A6

Switches (cont)

Ckt. No.	Tektronix Part No.		Description	S/N Range
	Unwired	Wired		
SW101	260-448		Slide	CH 1 AC-DC-GND
SW110	260-607	*262-653	Rotary	CH 1 VOLTS/DIV
SW150†	*311-319			CH 1 CALIB
SW155††	260-442		Rotary	CH 1 INV/NORM
SW201	260-448		Slide	CH 2 AC-DC-GND
SW210	260-607	*262-653	Rotary	CH 2 VOLTS/DIV
SW250†††	*311-319			CH 2 CALIB
SW290††	260-442		Rotary	MODE
SW420	260-447		Slide	TRIGGER CH 1 ONLY PULL

Transformer

T263	*120-193	Toroid, 7T Bifilar
------	----------	--------------------

Electron Tubes

V113	Use *157-0121-00	7586, checked
V123	Use *157-0121-00	7586, checked
V213	Use *157-0121-00	7586, checked
V223	Use *157-0121-00	7586, checked
V344	154-187	6DJ8
V363	154-187	6DJ8
V384	154-361	8233
V394	154-361	8233

†SW150 and R139 furnished as a unit.

††SW155 and SW290 are concentric. Furnished as a unit.

††SW155 and SW290 are concentric. Furnished as a unit.

†††SW250 and R239 furnished as a unit.

IMPORTANT:

Circuit voltages measured with 20,000 Ω /volt VOM. All readings in VOLTS.

Voltage measurements are not absolute and may vary from unit to unit. For these measurements, a 30" flexible plug-in extension cable (012-066) was used to operate the Type 3A6 outside of the indicator unit plug-in compartment.

The time-base used with the Type 3A6 was set for automatic triggering at a 1 millisecond/division sweep rate.

VOLTAGE READINGS were obtained under the following conditions (control settings apply to both channels):

Input Signal	None
AC DC GND	GND
VOLTS/DIV	.2
VARIABLE	CALIB
POSITION	Centered
MODE	CH 1
INV (CH 1) NORM	NORM
TRIGGER	Pushed in

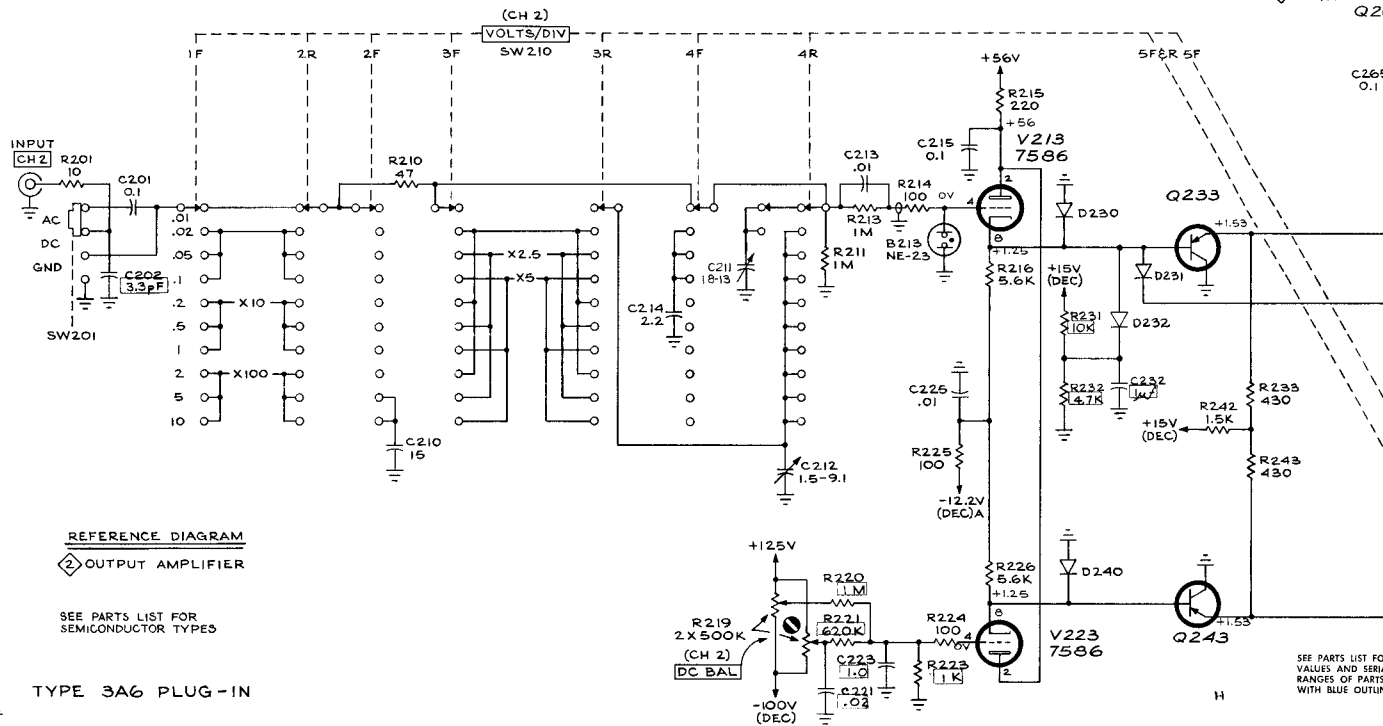
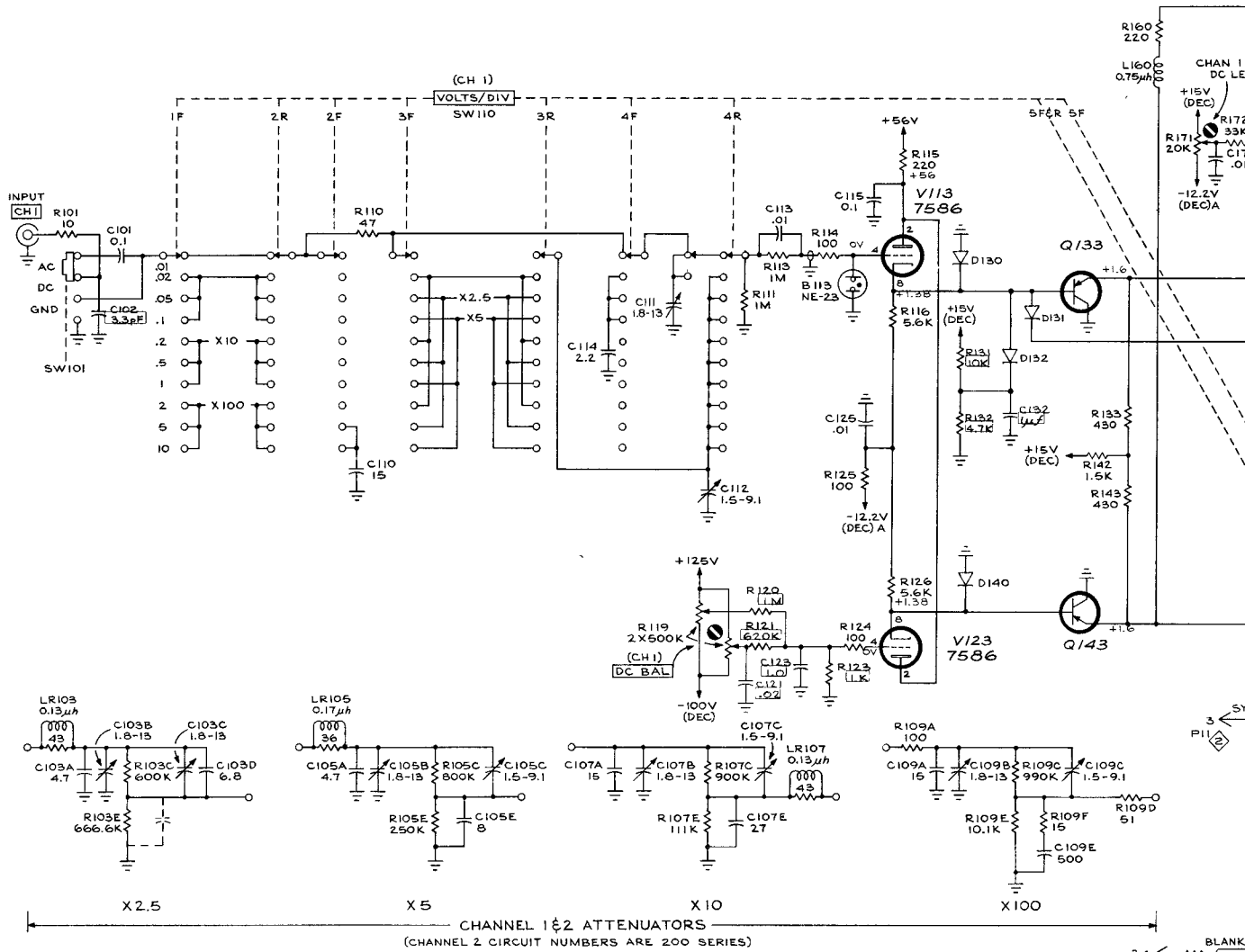

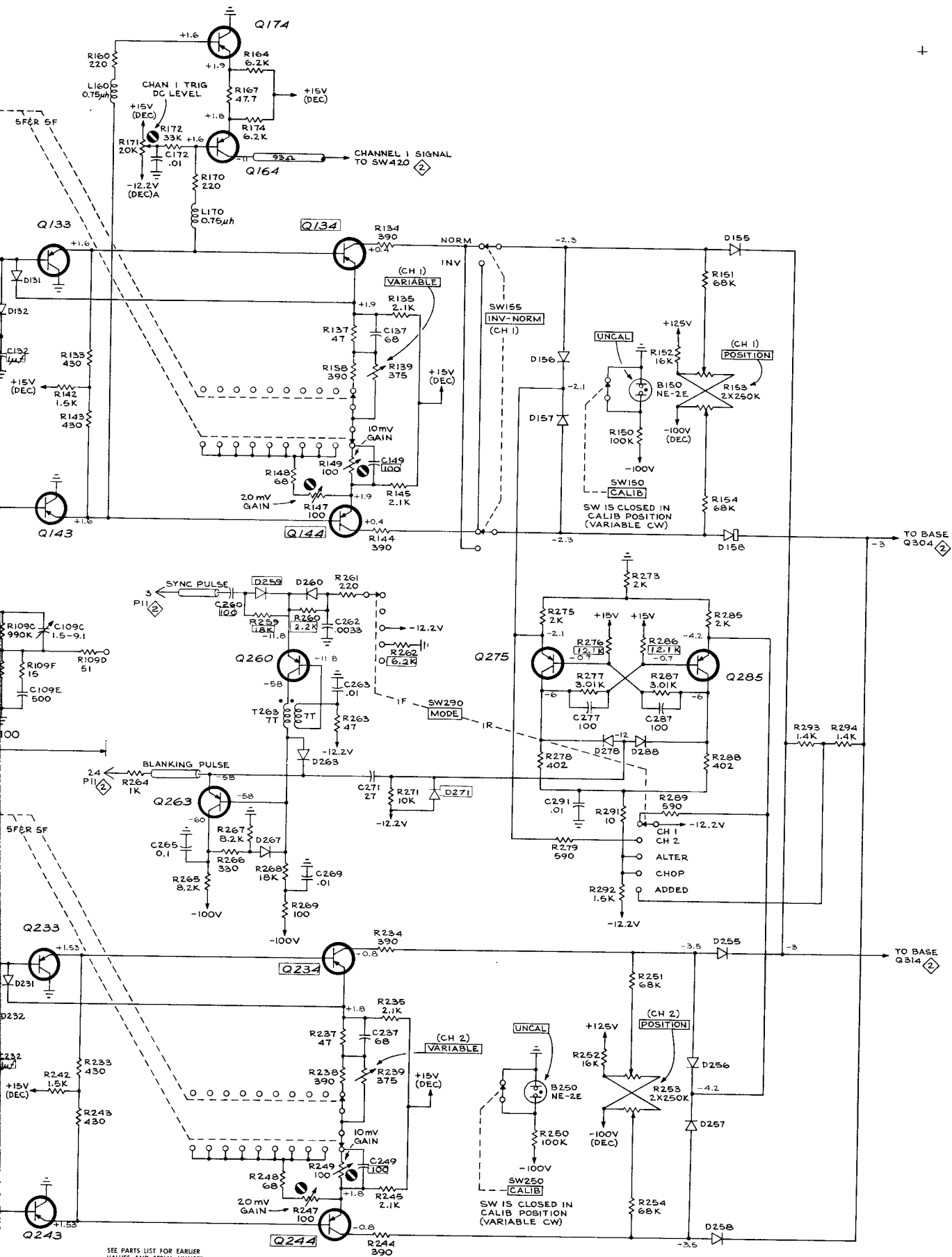

SEE PARTS LIST FOR EARLIER VALUES AND SERIAL NUMBER RANGES OF PARTS MARKED WITH BLUE OUTLINE

INPUT AMPLIFIER & SWITCHING CIRCUIT

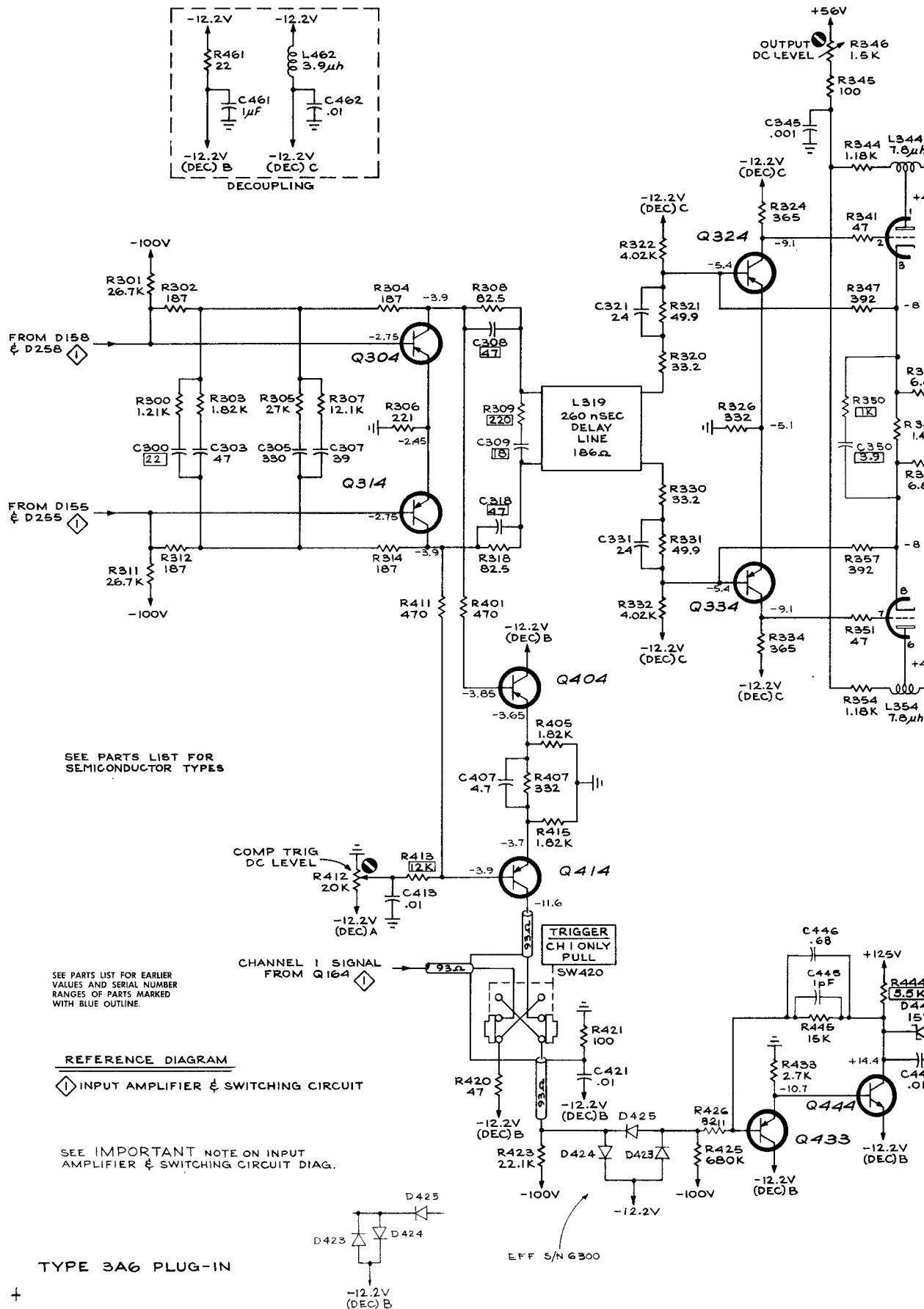
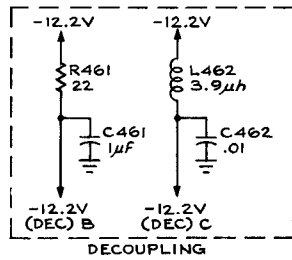

SEE PARTS LIST FOR SEMICONDUCTOR TYPES

SEE PARTS LIST FOR EARLIER VALUES AND SERIAL NUMBER RANGES OF PARTS MARKED WITH BLUE OUTLINE.

REFERENCE DIAGRAM

◇ INPUT AMPLIFIER & SWITCHING CIRCUIT

SEE IMPORTANT NOTE ON INPUT AMPLIFIER & SWITCHING CIRCUIT DIAG.

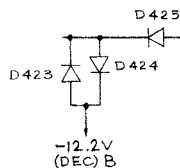

TYPE 3A6 PLUG-IN

+

EFF S/N 6300

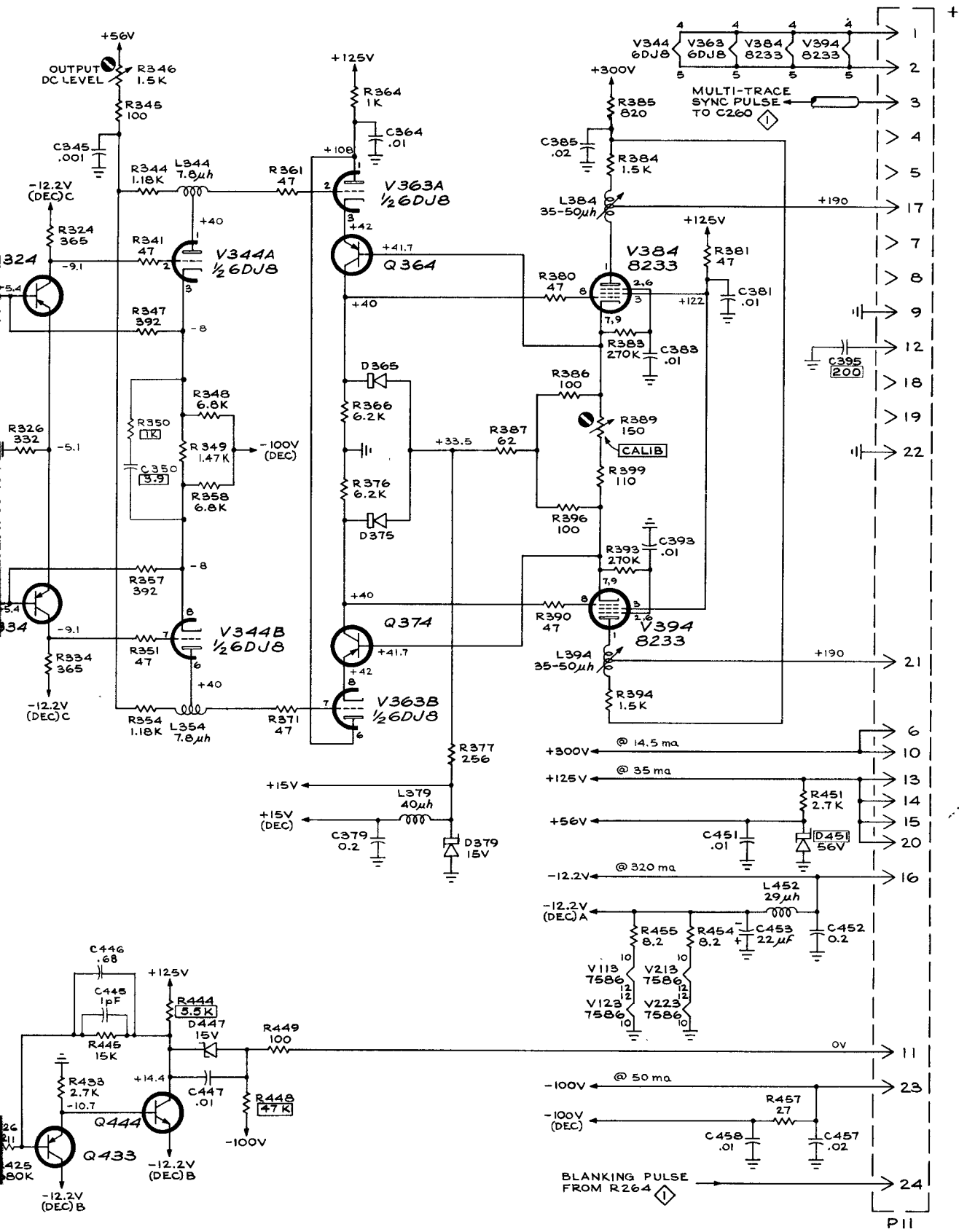

269
 OUTPUT AMPLIFIER